



Model: SE182E ERV

VENTILATION PERFORMANCE

ENERGY PERFORMANCE

EXT. STATIC PRESSURE in wg (Pa)	NET SUPPLY AIR FLOW cfm (l/s)	SUPPLY TEMP. °F (°C)	NET AIR FLOW cfm (l/s)	AVERAGE POWER Watts	SENSIBLE RECOVERY EFFICIENCY	ADJUSTED SENSIBLE RECOVERY EFFICIENCY
0.1 (25)	212 (100)	+32 (0)	52 (25)	84	80%	90%
0.2 (50)	201 (95)	+32 (0)	63 (30)	94	78%	88%
0.3 (75)	191 (90)	+32 (0)	74 (35)	104	75%	85%
0.4 (100)	180 (85)	-13 (-25)	72 (34)	104	55%	60%
0.5 (125)	170 (80)					
0.6 (150)	159 (75)				Total Recovery Efficiency	Adjusted Total Recovery Efficiency
0.7 (175)	148 (70)	95 (35)	63 (30)	98	38	44
0.8 (200)	133 (63)					
0.9 (225)	121 (57)					
1.0 (250)	106 (50)					
1.1 (275)	95 (45)					
1.2 (300)	85 (40)					
1.3 (325)	74 (35)					
1.4 (350)	59 (28)					



CABINET/CORE: Collar size: 6-inch (127mm). The case is constructed of 0.032 painted aluminum with a white enamel finish. The cabinet is fully insulated with 1-inch closed-cell polyisocyanurate foam. The unit is equipped with a cross-flow core that recovers both sensible and latent energy. Shipping weight: 40 lb (18 kg).

MOUNTING: Adjustable hanging straps. 2-door system for easy field reversal. Minimum clearance of 16 inches recommended for removal of ERV core; 6 inches for control access. **No drain required.**

CERTIFICATION: cCSAus, C22.2, HVI. **ELECTRICAL:** 120V/1/60 Hz. 280W, 2.3A

BLOWERS: Two backward curve impellers using PSC motors and permanently sealed bearings.

ADDITIONAL FEATURES:

- Meets ONBC A1, A2, A4, A5, A6 Compliance Packages
- Furnace/Air handler interlock
- Adaptive frost prevention algorithm: when needed to avoid frosting of the core, the supply fan shuts down. The duration and interval adjust based on outdoor and delivered air temperatures. **NO DRAIN** required.
- Balancing: differential pressure ports on the doors allow air measurements without a flow grid in ductwork. Independent speed adjustment of either supply or exhaust motor in BOTH high and low speed. Balancing dampers not required.
- 24 V circuit protection with self resetting fuse
- Washable MERV 6 air filters included
- 12 VDC or 24 VAC remote control options with the following Nu-Air controls:

12 VDC	24 VAC
Lumina (NAV-561): Low speed, high speed, intermittent, 20/40 standby, 20-40-60 minute timer, filter service alert (clock) Legacy Controls (retrofit/replacement applications) ES-M1, ES-M2 ES-T1: 20-40-60-minute high speed timer	*NAV-460: 20-40-60 minute high speed timer (up to 5) DSTAT-1: Humidity control Win-1: Humidity control/ OFF/ STBY/ Continuous/ Intermittent/ Full-time high speed WIN-20: 20-minute high speed timer (up to 6) Also: 24 VAC, dry contacts for 3rd party switches *NAV-460 not compatible with ES-T1, WIN-20 timers

Warranty: There is a 5-year warranty on all internal components. The heat recovery core has a 5-year warranty.



Model: SE182E ERV

Item	Feature
1	Backward Curved Impellers (2)
2	Cross Flow Enthalpy Core
3	Control Terminal
4	Filters
5	Hanging mounts
6	Balancing Ports

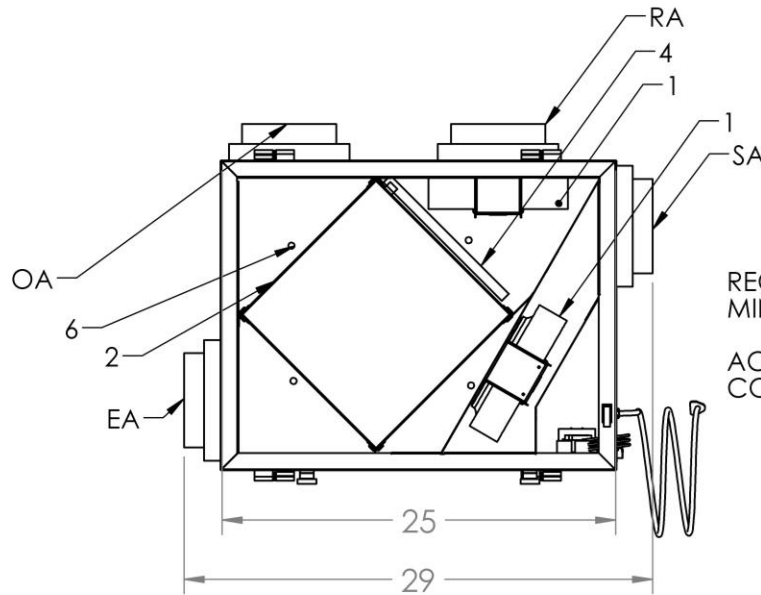
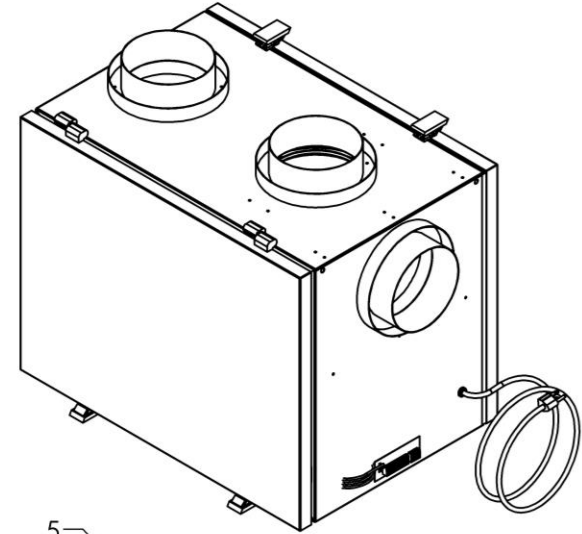
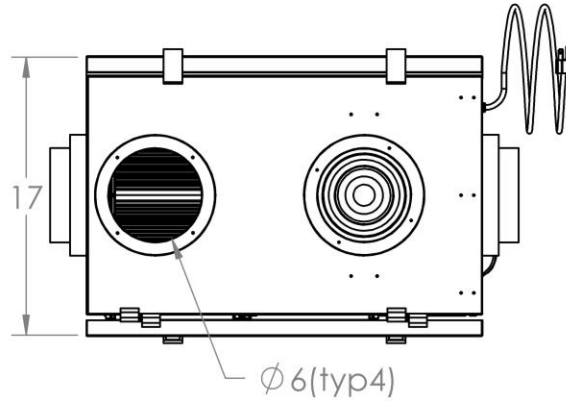

RECOMMENDED
MINIMUM CLEARANCE: 22

ACCESS SIDE 16 in
CONTROL SIDE 6 in

