



Model: ES100H (HRV)

VENTILATION PERFORMANCE			
EXT. STATIC PRESSURE	NET SUPPLY AIR FLOW	GROSS AIR FLOW	
in wg (Pa)	cfm (l/s)	SUPPLY cfm (l/s)	EXHAUST cfm (l/s)
0.1 (25)	127 (60)	131 (62)	167 (79)
0.2 (50)	117 (55)	121 (57)	155 (73)
0.3 (75)	104 (49)	108 (51)	140 (66)
0.4 (100)	93 (44)	95 (45)	127 (60)
0.5 (125)	81 (38)	83 (39)	112 (53)
0.6 (150)	68 (32)	70 (33)	100 (47)
0.7 (175)	51 (24)	53 (25)	85 (40)
0.8 (200)	34 (16)	36 (17)	70 (33)

ENERGY PERFORMANCE				
SUPPLY TEMP.	NET AIR FLOW	POWER CONSUMED	SENSIBLE RECOVERY EFFICIENCY	APPARENT SENSIBLE EFFECTIVENESS
°F (°C)	cfm (l/s)	Watts		
+32 (0)	64 (30)	52	66%	71%
+32 (0)	96 (45)	84	60%	66%
+32 (0)	116 (55)	102	57%	63%
-13 (-25)	64 (30)	74	58%	62%



CABINET/CORE: Collar size: 5-inch (127 mm). The case is constructed of 0.032 painted aluminum with a white enamel finish. The cabinet is fully insulated with 1-inch polystyrene. The unit is equipped with a polypropylene cross-flow heat exchange core. Shipping weight: 34 lbs (15 kg).

ELECTRICAL: 120V/1/60 Hz. 113W, 1 A

BLOWERS: Two backward curve impellers using PSC motors and permanently sealed bearings.

CERTIFICATION: cCSAus, CSA C22.2, ASHRAE 62.2, HVI

REVERSIBLE: internal components can be accessed **front or back**

ADDITIONAL FEATURES:

- Furnace interlock options: commands furnace blower when HRV is on or only on high speed
- Intelligent Defrost: duration and interval adjust to outdoor conditions below -5° C (23° F)
- **In defrost and recirculation modes, this unit will not induce indoor negative pressure nor recycle exhaust air; rather, it will redistribute ambient room air.**
- Balancing: differential pressure ports on door allow air measurements without flow grid in ductwork. Independent speed adjustment of either supply or exhaust motor in BOTH high and low speed.
- 24 V circuit protection with self resetting fuse
- Drain, hanger kit, polyester air filters included
- 12 VDC or 24 VAC remote control options with the following Nu-Air controls:

12 VDC	24 VAC
Lumina (NAV-561): Low speed, high speed, intermittent, 20/40 standby, 20-40-60 minute timer, filter service alert (clock) Legacy Controls (retrofit/replacement applications) ES-M1, ES-M2 ES-T1: 20-40-60-minute high speed timer	*NAV-460: 20-40-60 minute high speed timer (up to 5) DSTAT-1: Humidity control Win-1: Humidity control/ OFF/ STBY/ Continuous/ Intermittent/ Full-time high speed WIN-20: 20-minute high speed timer (up to 6) Also: 24 VAC, dry contacts for 3rd party switches *NAV-460 not compatible with ES-T1, WIN-20 timers

Defrost: When outdoor temperature falls to -5° C (23° F), an automatic timed defrost cycle is initiated. The fresh air motor will go to high speed and the exhaust air motor will turn off. A damper will shut off the cold supply port, directing ambient air through the core for defrosting. The unit will resume normal operation for a fixed duration, then the processor will read outdoor temperature and initiate defrost as necessary. Defrost varies with outdoor temperature.

Warranty: There is a 5-year warranty on all internal components. The heat recovery core has a 15-year warranty.



Model: ES100

Notes:

1. Backward curved impellers
2. Temperature activated defrost
3. Cross-flow core
4. Remote connections
5. Defrost damper
6. Filters (2) washable
7. Hanger nutserts
8. 1/2" Drains
9. 5" Collars
10. Defrost/Recirculation from neutral space

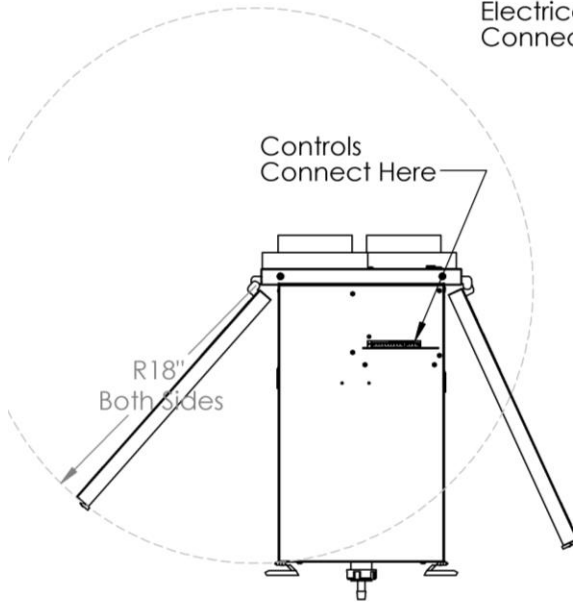
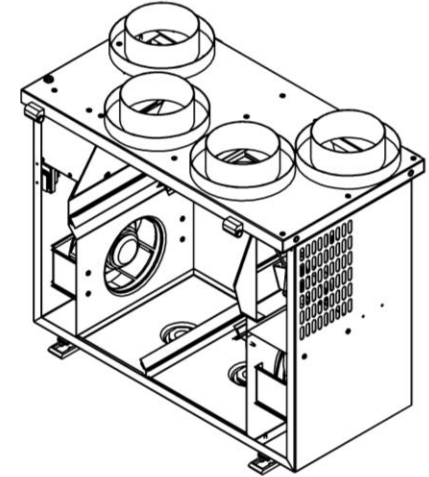
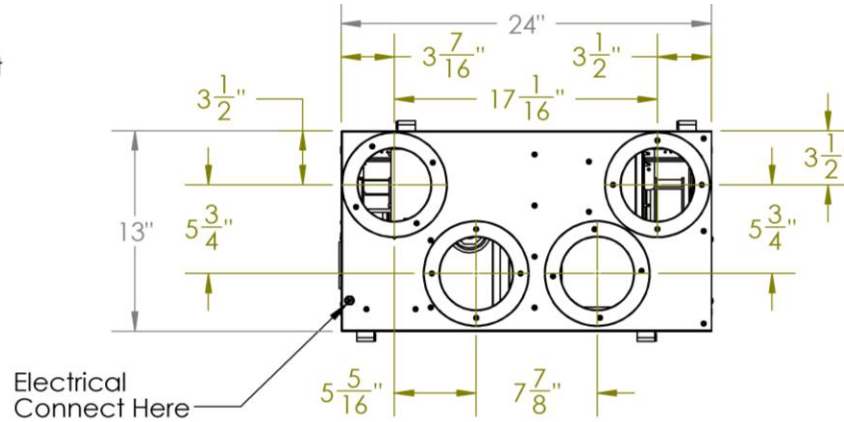

Unit Reversible
Doors are removable
if required for access
to core and routine
maintenance

