



Model: NU145H (HRV)

VENTILATION PERFORMANCE				
EXT. STATIC PRESSURE	NET SUPPLY AIR FLOW	GROSS AIR FLOW		
in wg (Pa)	cfm (l/s)	SUPPLY	EXHAUST	
		cfm (l/s)	cfm (l/s)	
0.1 (25)	143 (67)	144 (68)	174 (82)	
0.2 (50)	124 (58)	125 (59)	150 (71)	
0.3 (75)	109 (51)	110 (52)	135 (64)	
0.4 (100)	100 (47)	101 (48)	122 (58)	
0.5 (125)	92 (43)	93 (44)	104 (49)	
0.6 (150)	78 (37)	79 (37)	93 (44)	
0.7 (175)	63 (30)	64 (30)	86 (41)	
0.8 (200)	46 (22)	47 (22)	72 (34)	

ENERGY PERFORMANCE				
SUPPLY TEMP.	NET AIR FLOW	POWER CONSUMED	SENSIBLE RECOVERY EFFICIENCY	APPARENT SENSIBLE EFFECTIVENESS
°F (°C)	cfm (l/s)	Watts		
+32 (0)	64 (30)	50	71%	80%
+32 (0)	96 (45)	80	64%	73%
+32 (0)	116 (55)	90	63%	70%
-13 (-25)	60 (28)	69	64%	82%



CABINET/CORE: Collar size: 6-inch (152 mm); 5th Port: 5-inch (127 mm). The case is constructed of 0.032 painted aluminum with a white enamel finish. The cabinet is fully insulated with 1-inch polystyrene. The unit is equipped with a polypropylene cross-flow heat exchange core. Shipping weight: 30 lb (13.6 kg).

CERTIFICATION: cCSAus, C22.2, ASHRAE 62.2, HVI **ELECTRICAL:** 120V/1/60 Hz. 115W, 1A

BLOWERS: Two backward curve impellers using PSC motors and permanently sealed bearings.

REVERSIBLE:
internal components
can be accessed
front or back.

ADDITIONAL FEATURES:

- Furnace interlock options: commands furnace blower when HRV is on or only on high speed
- Intelligent Defrost: duration and interval adjust to outdoor conditions below -5° C (23° F)
- **In defrost and recirculation modes, this unit will not induce indoor negative pressure nor recycle exhaust air; rather, it will redistribute ambient room air.**
- Balancing: differential pressure ports on door allow air measurements without flow grid in ductwork. Independent speed adjustment of either supply or exhaust motor in BOTH high and low speed.
- 24 V circuit protection with self resetting fuse
- Drain, hanger kit, polyester air filters included
- 12 VDC or 24 VAC remote control options with the following Nu-Air controls:

12 VDC	24 VAC
Lumina (NAV-561): Low speed, high speed, intermittent, 20/40 standby, 20-40-60 minute timer, filter service alert (clock)	*NAV-460: 20-40-60 minute high speed timer (up to 5)
Legacy Controls (retrofit/replacement applications) ES-M1, ES-M2 ES-T1: 20-40-60-minute high speed timer	DSTAT-1: Humidity control Win-1: Humidity control/ OFF/ STBY/ Continuous/ Intermittent/ Full-time high speed WIN-20: 20-minute high speed timer (up to 6) Also: 24 VAC, dry contacts for 3rd party switches <i>*NAV-460 not compatible with ES-T1, WIN-20 timers</i>

Defrost: When outdoor temperature falls to -5° C (23° F), an automatic timed defrost cycle is initiated. The fresh air motor will go to high speed and the exhaust air motor will turn off. A damper will shut off the cold supply port, directing ambient air through the core for defrosting. The unit will resume normal operation for a fixed duration, then the processor will read outdoor temperature and initiate defrost as necessary. Defrost varies with outdoor temperature.

Warranty: There is a 5-year warranty on all internal components. The heat recovery core has a 15-year warranty.

Notes:

This product earned the ENERGY STAR® by meeting strict energy efficiency guidelines set by Natural Resources Canada and the US EPA. It meets ENERGY STAR requirements only when used in Canada.



Model: NU145

Notes:

- 1. Outside air
- 2. Supply air
- 3. Return air
- 4. Exhaust air
- 5. 5" Recirculation port
- 6. Backward curved impellers
- 7. Defrost damper
- 8. Cross flow core
- 9. Remote connections
- 10. Washable filters (2)
- 11. Hanger nutserts (4)
- 12. 1/2" Drains (2)
- 13. 5" Collar
- 14. 6" Collars (4)

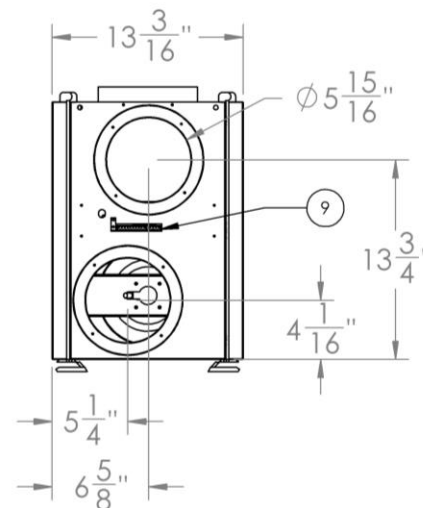
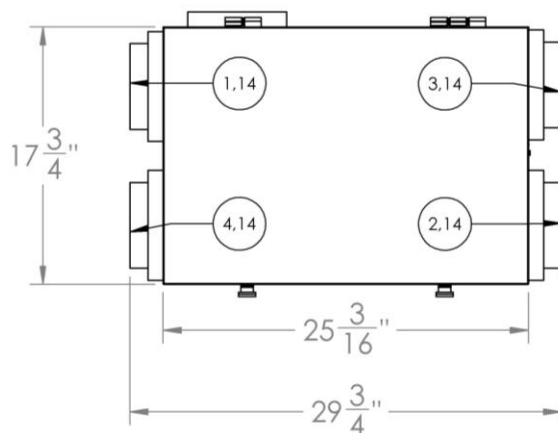
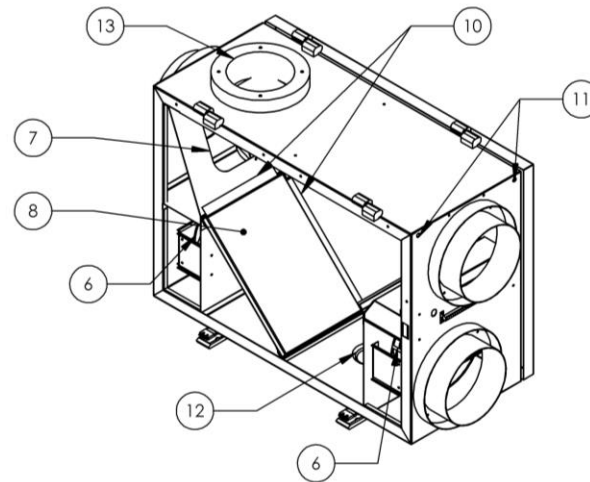
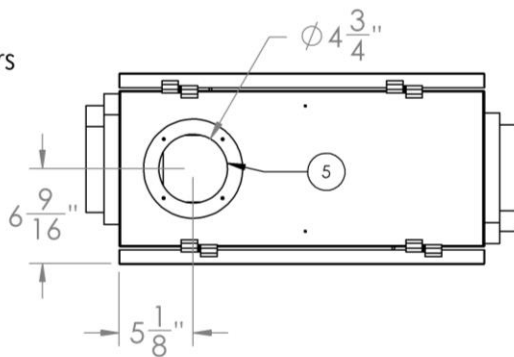

Unit is Reversible
2 Doors are removable
if required for access
to core and routine
maintenance