

# NU600HRV PRODUCT INFORMATION SHEET

## CORE

Polypropylene crossflow core. Nu-Air part #PC1720A.  
Dimensions: 17.5"L x 17.5"W x 21"H.

## ELECTRICAL

115Volt, 60Hz. Single point power connection.  
Unit FLA: 4.4 Amps MCA: 5.5 Amps MOCP: 15 Amps

## MOTORS

Fractional 2 speed PSC motors. 1275 RPM. Nu-Air Part #50104. Independent speed adjustment of either supply or exhaust motor in both high and low speed.

## BLOWERS

Two forward curve, dual inlet fans using permanently sealed bearings.

## CABINET

The case is constructed of .050 pre-painted white aluminum that is fully insulated with 1" foil faced fibreglass insulation.  
Drain connections: 1/2"(2). Nu-Air drain fitting part #50362. Cabinet Dimensions: 42"L x 30"H x 23"W.  
Duct connections: 14" x 8".

## CONFIGURATION

Available in standard 'A' or reverse 'E' configuration. See drawings.

## ELECTRONICS

Integrated microprocessor. Built in interlock contacts.  
24V circuit protection with self resetting fuse.  
12VDC and/or 24V connection for remote control with mechanical switch or any Nu-Air control.

## DEFROST OPTIONS

Model **NU600FP** – Supply fan shuts down while exhaust air defrosts core.  
Model **NU600DP** – Bypass damper routes indoor air to defrost core.

**WEIGHT** – 170lbs/77.3kg

**SHIPPING WEIGHT** – 190lbs/86.2kg

## FILTERS

2 Filters @ 16" x 20" x 1".  
1" pleated MERV8 filters in supply and exhaust airstreams.  
MERV13 filter upgrade available upon request.

Filter	Type	Part #	Qty
MERV8	1" Pleated	50162	2
MERV13	1" Pleated	50807	2

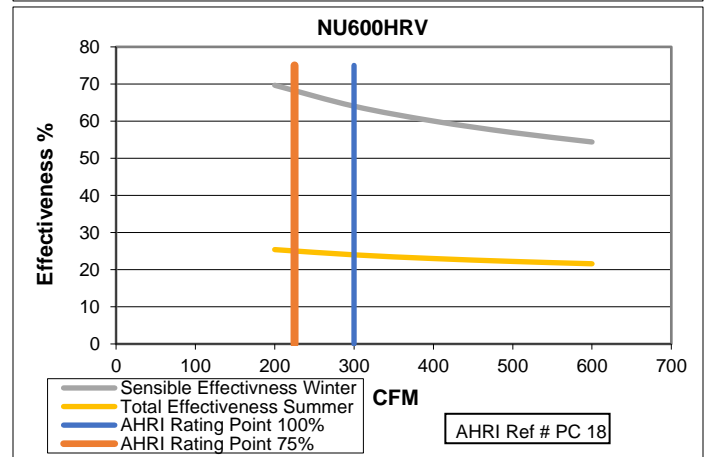
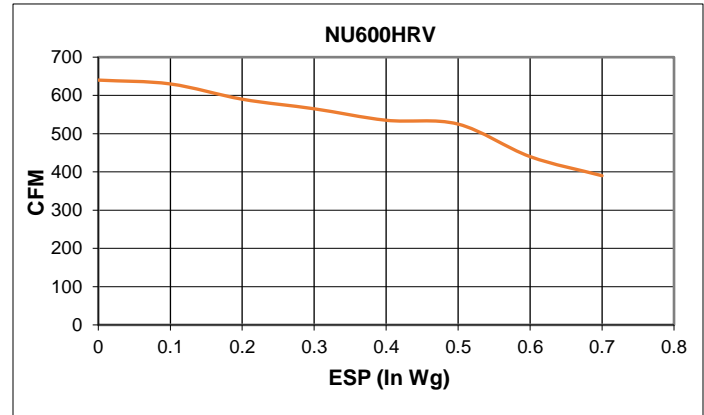

## CONTROL OPTIONS

### 12 VDC controls available

**Lumina (NAV-561)** - Digital wall mounted control c/w Dehumidistat, timer functions & filter change indicator

### 24 V controls available

- NAV-460** - 20/40/60 minute timer
- Dstat-1** - Humidity control
- WIN-1** - Humidity control c/w Off/Standby/Continuous/Intermittent
- WIN-20** - 20 minute push button timer (up to 6 per unit)
- Any dry contact switch** – By Others

## NOMENCLATURE EXAMPLE

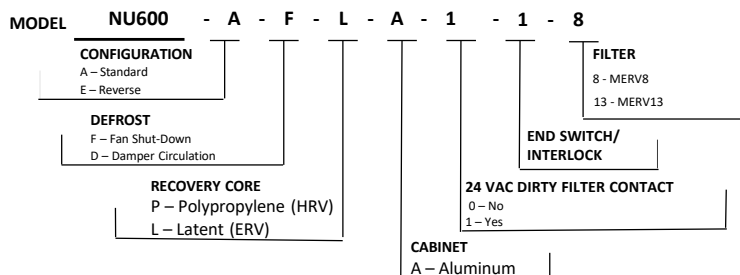

**WARRANTY** - Provided installation is in accordance with instruction, 15 year warranty on the HRV core and a 2 year warranty on replacement parts.

Distributed by:

# NU600 CONFIGURATION DRAWINGS

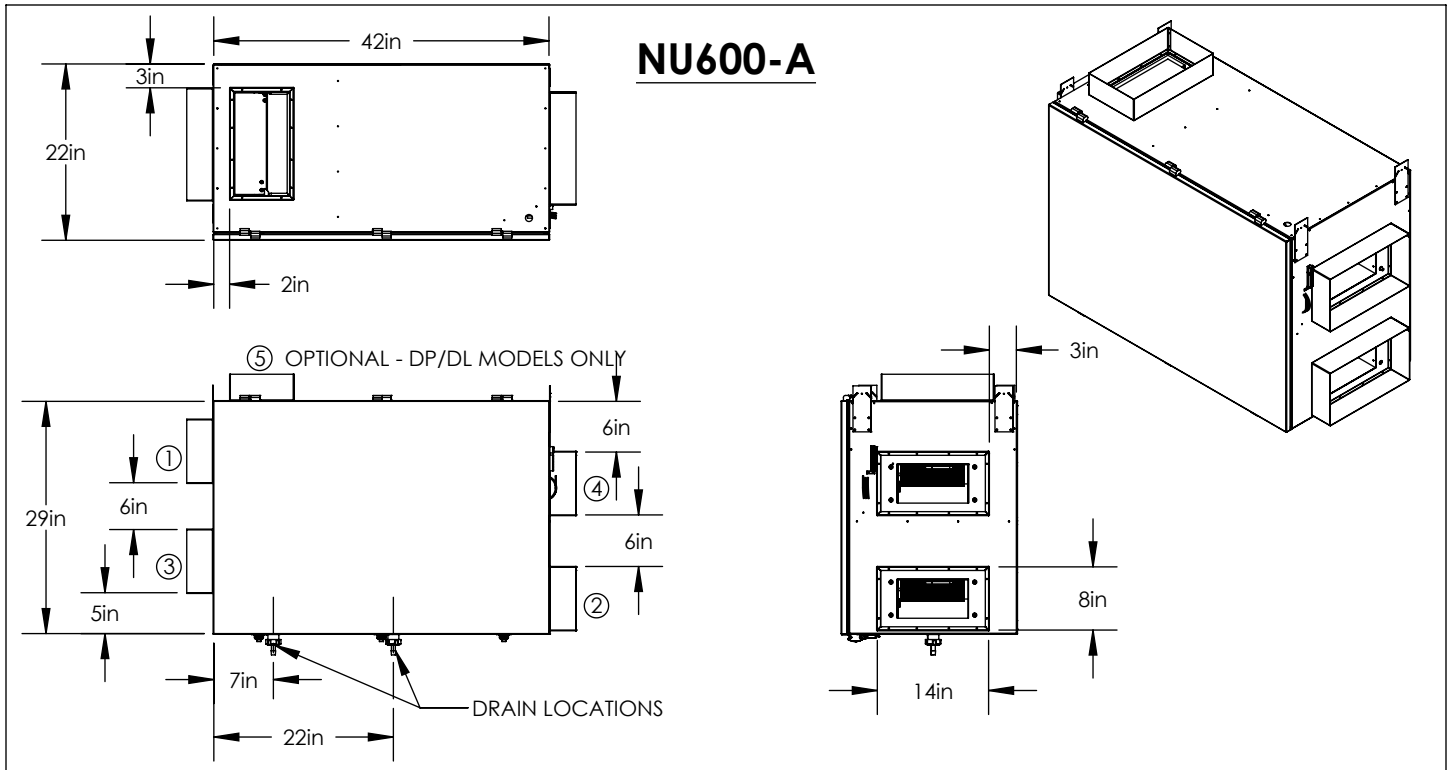

1 - OUTSIDE AIR / FRESH AIR FROM OUTSIDE	2 - SUPPLY AIR / FRESH AIR TO SPACE	3 - RETURN AIR / EXHAUST AIR FROM SPACE	4 - EXHAUST AIR / EXHAUST AIR TO OUTSIDE	5 - DEFROST AIR (OPTIONAL - DP/DL MODELS ONLY)
--	-------------------------------------	---	--	--

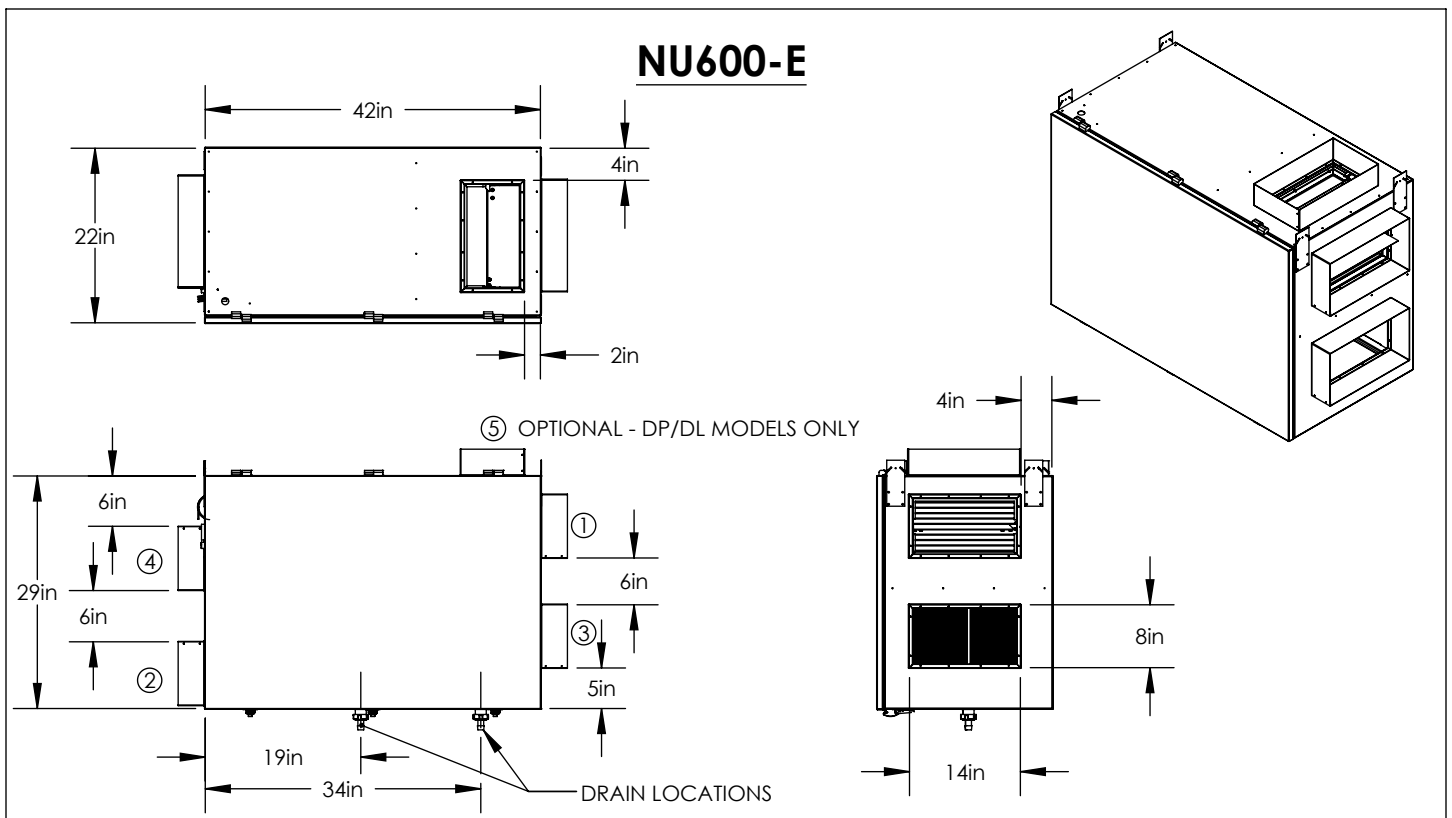

In the interest of product improvement, Nu-Air reserves the right to change specifications without notice.