

NU800HRV PRODUCT INFORMATION SHEET

CORE

Polypropylene crossflow core. Nu-Air part #PC1720A.
Dimensions: 17.5" L x 17.5" W x 20" H.

ELECTRICAL

115Volt, 60Hz. Single point power connection.
Unit FLA: 9.8 Amps MCA: 12.3 Amps MOCP: 20 Amps
Factory installed disconnect available upon request.

MOTORS

2 x 1/3HP 2 speed PSC motors. 1075 RPM. Nu-Air Part #50257.

BLOWERS

2 x DWDI direct drive blowers. Nu-Air Part #50778.

CABINET

The case is constructed of 22 Ga galvanized steel that is fully insulated with 1" foil faced fiberglass insulation.
Pre-painted white aluminum finish upgrade available upon request. Drain connections: 1/2"(2). Nu-Air drain fitting part #50362.
Cabinet Dimensions: 54" L x 30" H x 23" W.
Duct connections: 14" x 8".

CONFIGURATION

Available in standard 'C' or reverse 'G' configuration. See drawings.

ELECTRONICS

Integrated microprocessor. Built in interlock contacts.
24V circuit protection with self resetting fuse.
12VDC and/or 24V connection for remote control with mechanical switch or any Nu-Air control.

DEFROST OPTIONS

Model **NU800FP** – Supply fan shuts down while exhaust air defrosts core.
Model **NU800DP** – Bypass damper routes indoor air to defrost core.

WEIGHT – 255lbs/115.7kg **SHIPPING WEIGHT** – 280lbs/127kg

FILTERS

2 Filters @ 16" x 20" x 1".
1" pleated MERV8 filters in supply and exhaust airstreams.
MERV13 filter upgrade available upon request.
Dirty filter contacts available upon request.

Filter	Type	Part #	Qty
MERV8	1" Pleated	50162	2
MERV13	1" Pleated	50807	2

NOMENCLATURE EXAMPLE

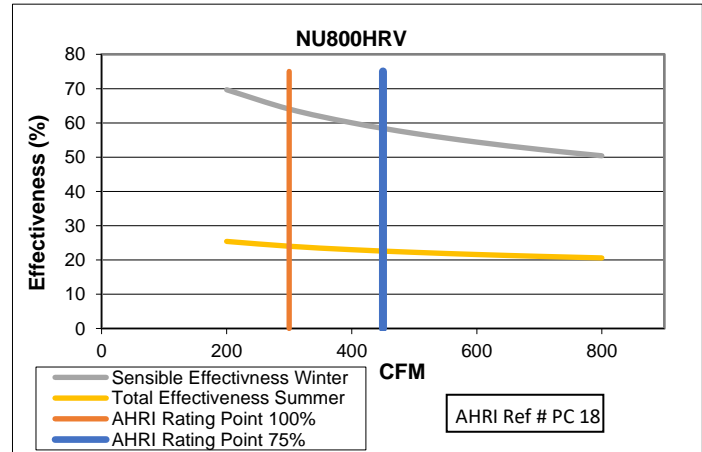
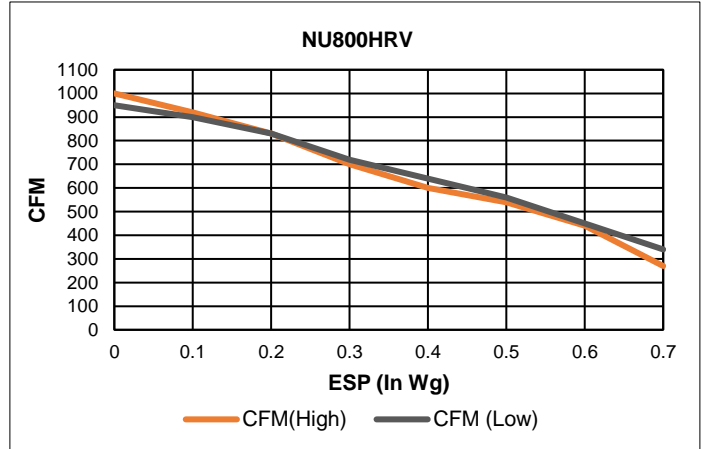
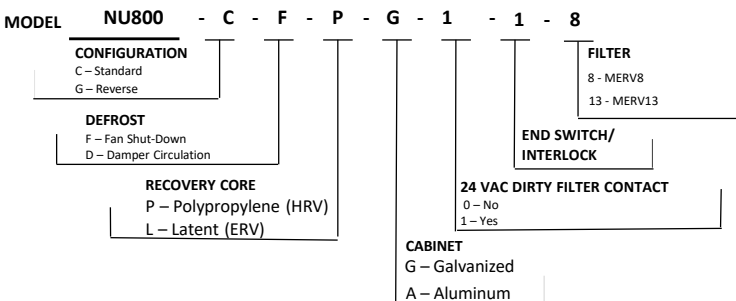

CONTROL OPTIONS

12 VDC controls available

Lumina (NAV-561) - Digital wall mounted control c/w Dehumidistat, timer functions & filter change indicator

24 V controls available

- NAV-460** - 20/40/60 minute timer
- Dstat-1** - Humidity control
- WIN-1** – Humidity control c/w Off/Standby/Continuous/Intermittent
- WIN-20** – 20 minute push button timer (up to 6 per unit)
- Any dry contact switch** – By Others

WARRANTY - Provided installation is in accordance with instruction, 15 year warranty on the HRV core and a 2 year warranty on replacement parts.

Distributed by:

NU800 CONFIGURATION DRAWINGS

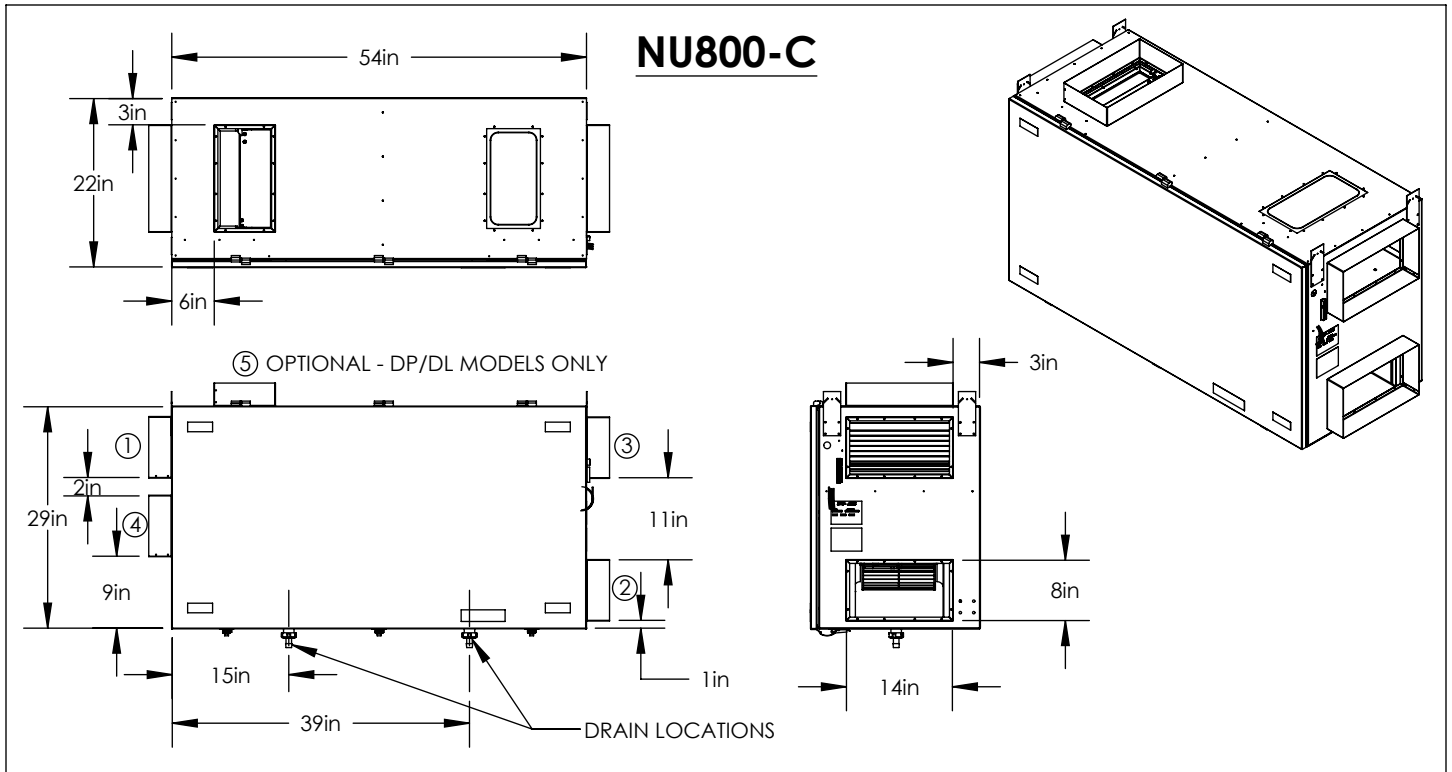

1 - OUTSIDE AIR / FRESH AIR FROM OUTSIDE	2 - SUPPLY AIR / FRESH AIR TO SPACE	3 - RETURN AIR / EXHAUST AIR FROM SPACE	4 - EXHAUST AIR / EXHAUST AIR TO OUTSIDE	5 - DEFROST AIR (OPTIONAL - DP/DL MODELS ONLY)
--	-------------------------------------	---	--	--

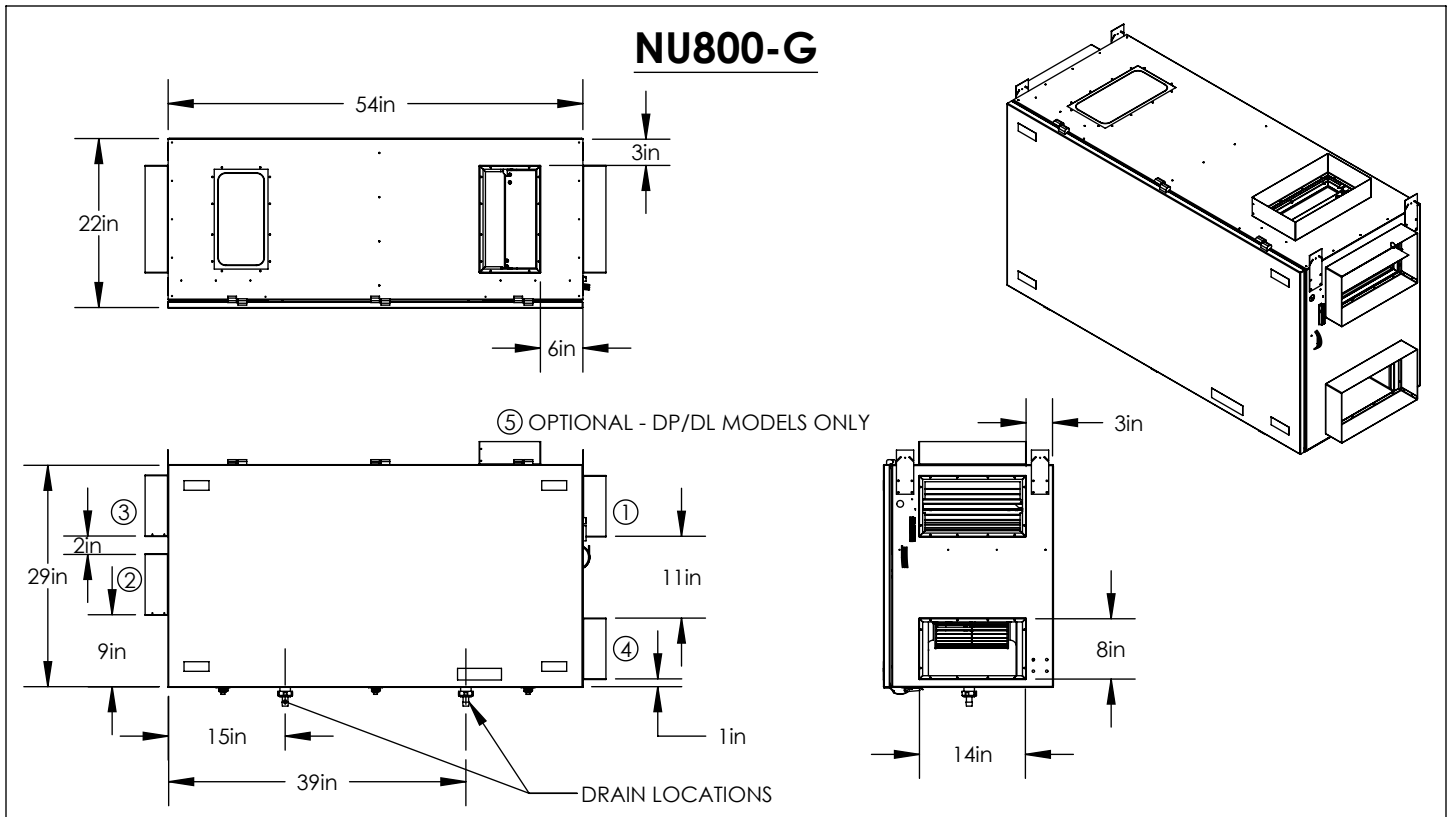

In the interest of product improvement, Nu-Air reserves the right to change specifications without notice.