

NU1600HRV PRODUCT INFORMATION SHEET

CORE

Polypropylene crossflow core. 2 sections. Nu-Air part #PC2314A. Dimensions: 24" L x 24" W x 28" H.

ELECTRICAL

208-230 Volt, 60Hz. Single point power connection. Unit FLA: 13 Amps MCA: 16.3 Amps MOCP: 25 Amps Factory installed disconnect available upon request.

MOTORS

2 x 1HP 2 speed PSC motors. 1075 RPM. Nu-Air Part #50590.

BLOWERS

2 x DWDI direct drive blowers. Nu-Air Part #50122.

CABINET

The case is constructed of 22 Ga galvanized steel that is fully insulated with 1" foil faced fibreglass insulation. Pre-painted white aluminum finish upgrade available upon request. Drain connections: 1/2" (2). Nu-Air drain fitting part #50362. Cabinet Dimensions: 64" L x 38" H x 30" W. Duct connections: 20" x 10".

CONFIGURATION

Available in standard 'C' or reverse 'G' configuration. See drawings.

ELECTRONICS

Integrated microprocessor. Built in interlock contacts. 24V circuit protection with self resetting fuse. 12VDC and/or 24V connection for remote control with mechanical switch or any Nu-Air control.

DEFROST OPTIONS

Model **NU1600FP** – Supply fan shuts down while exhaust air defrosts core. Model **NU1600DP** – Bypass damper routes indoor air to defrost core.

WEIGHT – 355lbs/161kg **SHIPPING WEIGHT** – 405lbs/183.7kg

FILTERS

2 Filters @ 12" x 24" x 1" & 2 Filters @ 16" x 24" x 1". 1" pleated MERV8 filters in supply and exhaust airstreams. MERV13 filter upgrade available upon request. Dirty filter contacts available upon request.

Filter	Type	Part #'s	Qty
MERV8	1" Pleated	50016 & 50410	2 Each
MERV13	1" Pleated	50809 & 50808	2 Each

NOMENCLATURE EXAMPLE

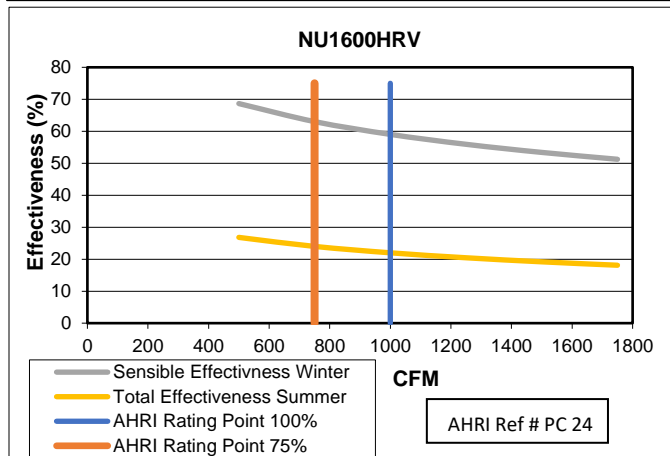
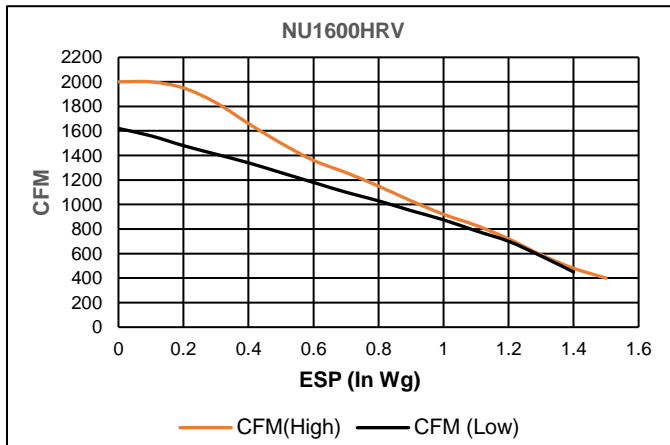
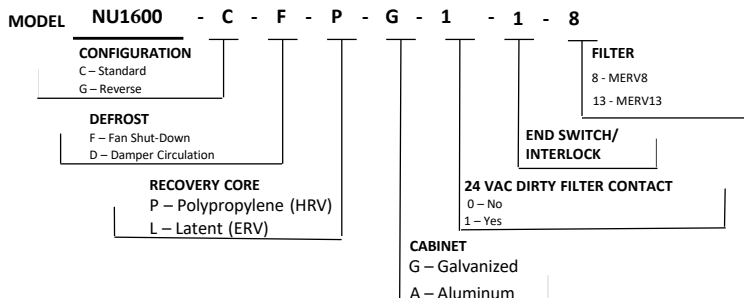

CONTROL OPTIONS

12 VDC controls available

Lumina (NAV-561) - Digital wall mounted control c/w Dehumidistat, timer functions & filter change indicator

24 V controls available

NAV-460 - 20/40/60 minute timer
Dstat-1 - Humidity control
WIN-1 - Humidity control c/w Off/Standby/Continuous/Intermittent
WIN-20 - 20 minute push button timer (up to 6 per unit)
Any dry contact switch - By Others

WARRANTY - Provided installation is in accordance with instruction, 15 year warranty on the HRV core and a 2 year warranty on replacement parts.

Distributed by:

NU1600 CONFIGURATION DRAWINGS

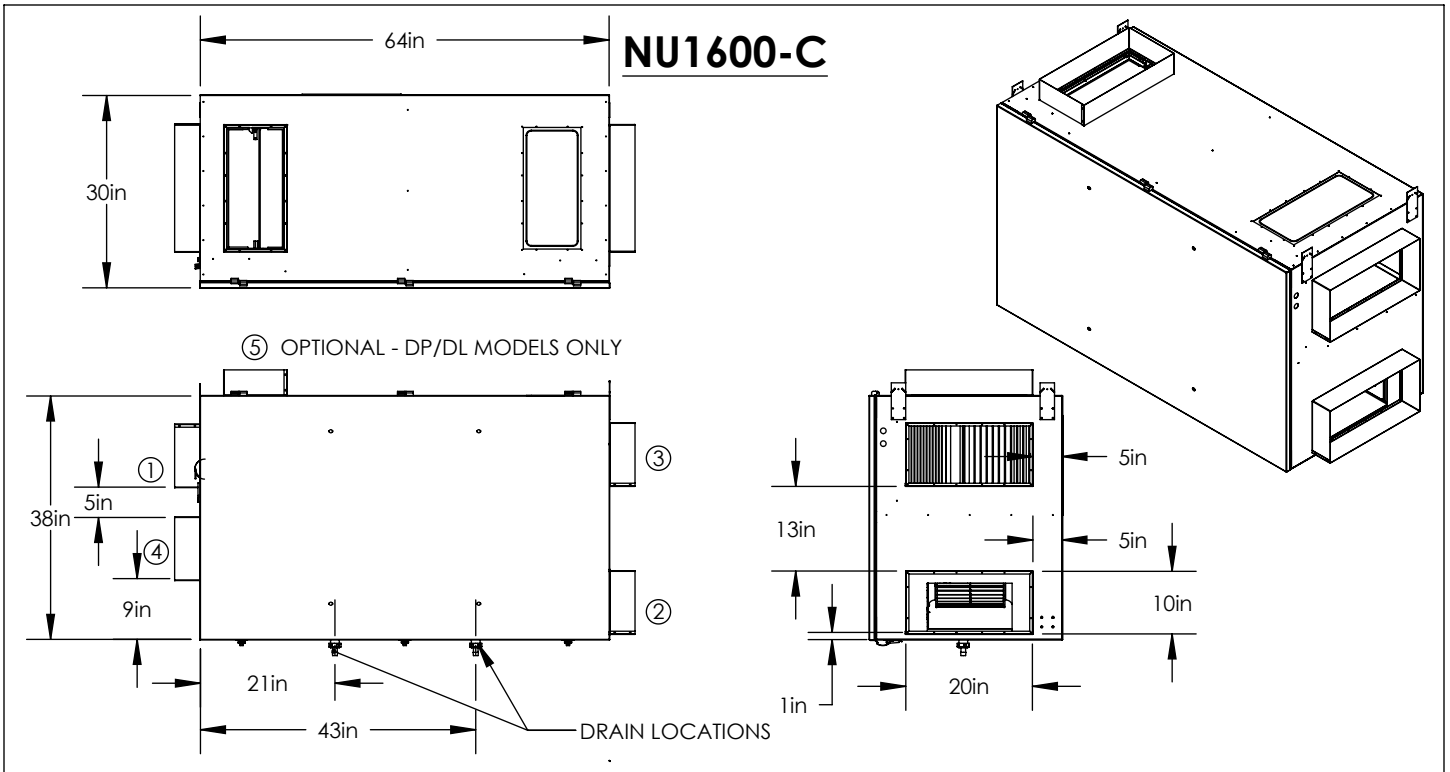

1 - OUTSIDE AIR / FRESH AIR FROM OUTSIDE	2 - SUPPLY AIR / FRESH AIR TO SPACE	3 - RETURN AIR / EXHAUST AIR FROM SPACE	4 - EXHAUST AIR / EXHAUST AIR TO OUTSIDE	5 - DEFROST AIR (OPTIONAL - DP/DL MODELS ONLY)
--	-------------------------------------	---	--	--

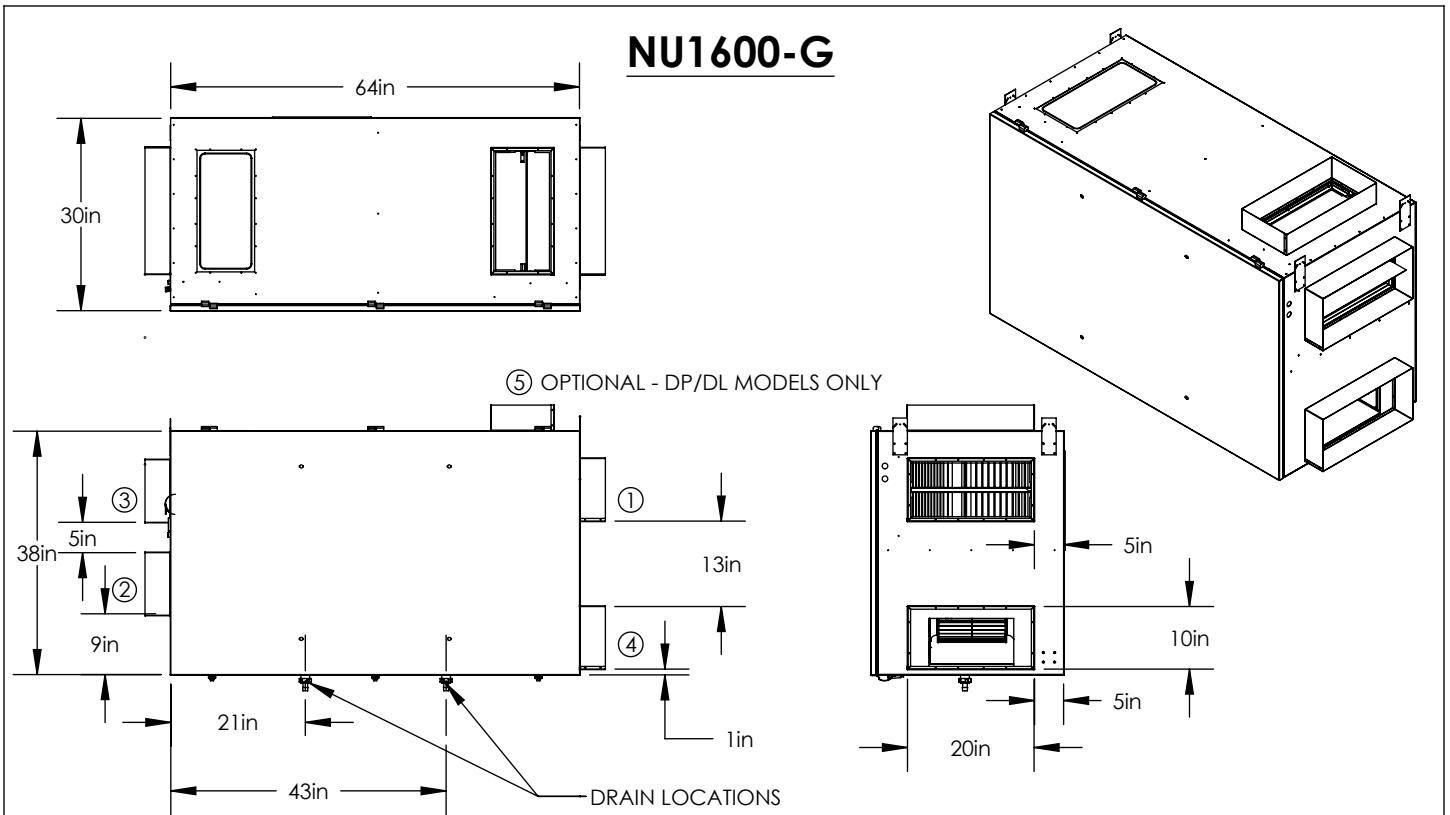

In the interest of product improvement, Nu-Air reserves the right to change specifications without notice.