



Model: ES160E (ERV)

VENTILATION PERFORMANCE			
EXT. STATIC PRESSURE	NET SUPPLY AIR FLOW	GROSS AIR FLOW	
		SUPPLY	EXHAUST
in wg (Pa)	cfm (l/s)	cfm (l/s)	cfm (l/s)
0.1 (25)	153 (72)	159 (75)	153 (72)
0.2 (50)	140 (66)	146 (69)	144 (68)
0.3 (75)	127 (60)	131 (62)	131 (62)
0.4 (100)	112 (53)	117 (55)	121 (57)
0.5 (125)	97 (46)	102 (48)	108 (51)
0.6 (150)	81 (38)	85 (40)	97 (46)
0.7 (175)	61 (29)	64 (30)	89 (42)

ENERGY PERFORMANCE					
SUPPLY TEMP.	NET AIR FLOW	POWER CONSUMED	SENSIBLE RECOVERY EFFICIENCY	APPARENT SENSIBLE EFFECTIVENESS	NET MOISTURE TRANSFER
°F (°C)	cfm (l/s)	Watts			
+32 (0)	64 (30)	60	74	80	0.74
+32 (0)	114 (54)	100	68	74	0.70
*TRE, ATRE					
95 (35)	66 (31)	60	48, 52	72	0.45

***Total Recovery Efficiency (TRE), Adjusted Total Recovery Efficiency (ATRE)**

CABINET/CORE: Collar size: 6-inch (152.4 mm). The case is constructed of 0.032 painted aluminum with a white enamel finish. The cabinet is fully insulated with 1-inch (CFC-free) polystyrene. The unit is equipped with an enthalpy cross-flow heat exchange core.



CERTIFICATION: cCSAus, CSA C22.2, ASHRAE 62.2, HVI

ELECTRICAL: 120V/1/60 Hz. 127W, 1.0 A

BLOWERS: Two backward curve impellers using PSC motors and permanently sealed bearings.

ADDITIONAL FEATURES:

- Furnace interlock options: commands furnace blower when HRV is on or only on high speed
- Intelligent Defrost: duration and interval adjust to outdoor conditions below -5° C (23° F)
- Balancing: Door-mounted differential pressure ports allow air measurements without the need of a flow grid in the ductwork. independent speed adjustment of either supply or exhaust motor in BOTH high and low speed
- 24 V circuit protection with self resetting fuse
- Drain, hanger kit, polyester air filters included
- 12 VDC or 24 VAC remote control options:

12 VDC	24 VAC
Lumina (NAV-561): Low speed, high speed, intermittent, 20/40 standby, 20-40-60 minute timer, filter service alert (clock) Legacy Controls (retrofit/replacement applications) ES-M1, ES-M2 ES-T1: 20-40-60-minute high speed timer	*NAV-460: 20-40-60 minute high speed timer (up to 5) DSTAT-1: Humidity control Win-1: Humidity control/ OFF/ STBY/ Continuous/ Intermittent/ Full-time high speed WIN-20: 20-minute high speed timer (up to 6) Also: 24 VAC, dry contacts for 3rd party switches *NAV-460 not compatible with ES-T1, WIN-20 timers

Defrost: When outdoor temperature falls to -5° C (23° F), an automatic timed defrost cycle is initiated. The exhaust air motor will go to high speed and the fresh air motor will turn off for a set period. Normal operation will resume for a fixed duration, then the processor will read outdoor temperature and initiate defrost as necessary. Defrost varies with outdoor temperature.

Warranty: There is a 5-year warranty on all internal components. The heat recovery core has a 5-year warranty.

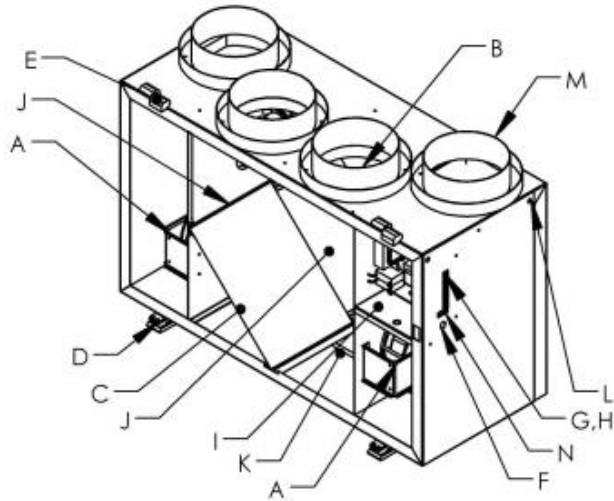

NOTES	
A	BACKWARD CURVE, DUAL INLET IMPELLER (2)
B	PROPORTIONAL DEFROST
C	HEAT EXCHANGE CORE - TOTAL
D	LATCH (2)
E	HINGE (2)
F	ELECTRICAL CONNECTION - CORD
G	REMOVABLE CONTROL TERMINALS
H	FURNACE INTERLOCK
I	ELECTRICAL BOX
J	FILTERS (2)
K	5/8" DRAIN (1)
L	HANGER MOUNTS (4)
M	DUCT COLLARS 6"
N	INDEPENDENT ELECTRONIC SPEED CONTROL HIGH AND LOW

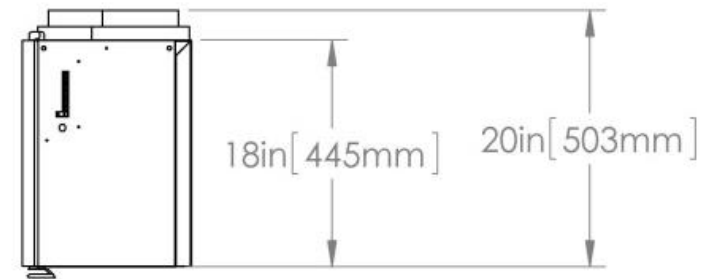
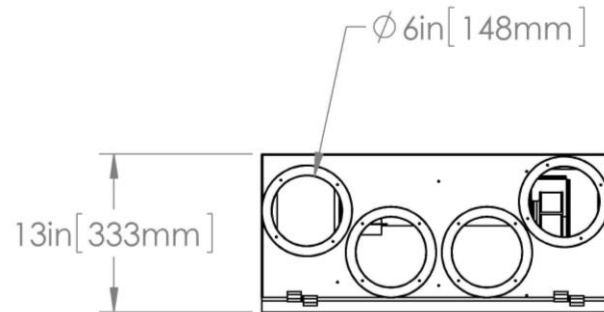
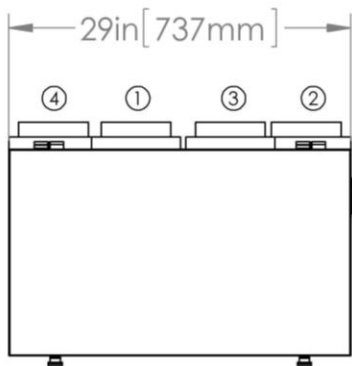

PORT DESIGNATIONS	
1	OUTSIDE AIR / FRESH AIR FROM OUTSIDE
2	SUPPLY AIR / FRESH AIR TO SPACE
3	RETURN AIR / EXHAUST AIR FROM SPACE
4	EXHAUST AIR / EXHAUST AIR TO OUTSIDE