



(Painted Option Shown)

2000 – 4000 CFM (NOMINAL)

INDOOR & ROOFTOP APPLICATIONS

MULTIPLE CONFIGURATIONS

FACTORY AIR BALANCED TO PROJECT SPECIFICATIONS

SPECIFICATIONS

CABINET/CONSTRUCTION

- Double wall construction, 22 ga (standard); 1 inch insulation
- Duct connections: 32" x 16". Weather hoods c/w bird screen (outdoor unit).
- Cabinet L x D x H: 93 x 45 x 51" (2362 x 1143 x 1296 mm)
- Removable access door with 1/4 turn, lockable handle
- Door-mounted differential pressure ports for air flow balancing
- NEMA 3R enclosure with non-fused disconnect
- 3/4" female NPT drain connections (left-front of unit)

Unit Weight: 1000 lbs (455 kg) Shipping Weight: 1325 lbs (600 kg)

Shipping L x D x H: 98 x 65 x 63" (NO hoods); 112 x 65 x 63" (W/ hoods)

CORE: Static Plate, Crossflow. Certified to AHRI 1060

- HRV: Polypropylene, 3 x p/n PC2314A (AHRI Ref.# PC24)
- ERV: Enthalpic membrane, 3 x p/n EC2314A (AHRI Ref.# EC24)
- FACE & BYPASS 1 x BP2314 (1030)+ 2 x PC2314 (HRV), or 2 x EC2314 (ERV)

MOTORS - FANS - FILTERS

- 2 x TEFC single-speed motors, 0.5-3.0 HP
- 2 x DWDI belt drive blowers, p/n 50072
- 6 x MERV 8 pleated filters (standard), 14 x 23.5 x 2", p/n 50092.

CONTROL

- Starter panel has Manual (full-time) or Auto/Remote (24 VAC) options.
- Factory installed VFD's present options for additional control means.
- 7-Day programmable timer, p/n 50395

FROST CONTROL – 6 OPTIONS (details see: PRODUCT SELECTION)

- None
- Face & Bypass (F&P)
- Exhaust only (temperature ON/OFF)
- F&P with Economizer
- Timed exhaust (temperature ON/Timer OFF)
- Recirculation

OPTIONS & ACCESSORIES

- 0.050 painted (white) aluminum outer skin
- Factory installed VFD's
- MERV 13 filters, 14 x 23.5 x 2", p/n 50856
- Dirty filter contacts/sensors
- Insulated, low leakage Outside Air backdraft damper (motorized)
- Exhaust Air backdraft damper (gravity OR motorized/insulated)
- Non-insulated roof curb 14" (standard). Custom sizes: 18", 24".
- 7-Day programmable timer, p/n 50395

WARRANTY - COMPLIANCE

- 2 years on internal components
- 15 years on polypropylene (HRV) cores; 5 years on Enthalpy (ERV) cores
- NU2035 conforms to CSA SPE1000

CFM/MOTOR TABLE: HRV

CFM	Motor Size	ESP = 0.25		ESP = 0.50		ESP = 0.75		ESP = 1.00		ESP = 1.25		ESP = 1.50		ESP = 1.75		ESP = 2.00		Motor Size	CFM
		BHP	RPM	BHP	RPM	BHP	RPM	BHP	RPM	BHP	RPM	BHP	RPM	BHP	RPM	BHP	RPM		
2000	1/2 HP	0.29	544	0.41	656	0.54	753	0.66	838	0.78	914	0.90	982	1.01	1043	1.12	1099	2000	
2100		0.31	553	0.44	663	0.58	759	0.70	843	0.83	918	0.95	986	1.07	1047	1.19	1104	2100	
2200		0.34	563	0.47	670	0.61	765	0.75	848	0.88	922	1.01	990	1.14	1052	1.26	1109	2200	
2300		0.37	572	0.50	678	0.65	770	0.79	853	0.93	927	1.07	995	1.20	1056	1.33	1113	2300	
2400		0.40	581	0.54	685	0.69	776	0.84	858	0.98	931	1.13	999	1.27	1061	1.41	1118	2400	
2500		0.43	591	0.58	692	0.73	782	0.89	863	1.04	936	1.19	1003	1.33	1065	1.48	1122	2500	
2600		0.46	600	0.62	699	0.78	788	0.94	868	1.09	940	1.25	1007	1.40	1069	1.56	1127	2600	
2700		0.50	609	0.66	707	0.82	794	0.99	872	1.15	945	1.31	1012	1.47	1074	1.63	1132	2700	
2800		0.54	618	0.70	714	0.87	800	1.04	877	1.21	949	1.38	1016	1.54	1078	1.71	1136	2800	
2900		0.58	628	0.74	721	0.92	805	1.09	882	1.27	954	1.44	1020	1.62	1083	1.79	1141	2900	
3000	3/4 HP	0.62	637	0.79	729	0.97	811	1.15	887	1.33	958	1.51	1025	1.69	1087	1.87	1145	3000	
3100		0.66	646	0.84	736	1.02	817	1.21	892	1.39	962	1.58	1029	1.77	1091	1.95	1150	3100	
3200		0.71	656	0.89	743	1.08	823	1.27	897	1.46	967	1.65	1033	1.84	1096	2.03	1155	3200	
3300		0.76	665	0.94	751	1.13	829	1.33	902	1.52	971	1.72	1038	1.92	1100	2.12	1159	3300	
3400		0.81	674	1.00	758	1.19	835	1.39	907	1.59	976	1.79	1042	2.00	1105	2.20	1164	3400	
3500		0.86	684	1.05	765	1.25	841	1.45	912	1.66	980	1.87	1046	2.08	1109	2.29	1168	3500	
3600		0.92	693	1.11	772	1.31	846	1.52	917	1.73	985	1.94	1050	2.16	1113	2.38	1173	3600	
3700		0.98	702	1.17	780	1.37	852	1.58	922	1.80	989	2.02	1055	2.24	1118	2.47	1178	3700	
3800		1.04	711	1.23	787	1.44	858	1.65	927	1.87	994	2.10	1059	2.33	1122	2.56	1182	3800	
3900		1.10	721	1.29	794	1.50	864	1.72	932	1.94	998	2.18	1063	2.41	1127	2.65	1187	3900	
4000	1.16	730	1.36	802	1.57	870	1.79	937	2.02	1003	2.26	1068	2.50	1131	2.74	1191	4000		

CFM/MOTOR TABLE: HRV – FACE AND BYPASS

CFM	Motor Size	ESP = 0.25		ESP = 0.50		ESP = 0.75		ESP = 1		ESP = 1.25		ESP = 1.50		ESP = 1.75		ESP = 2.00		Motor Size	CFM
		BHP	RPM	BHP	RPM	BHP	RPM	BHP	RPM	BHP	RPM	BHP	RPM	BHP	RPM	BHP	RPM		
1600	1/2 HP	0.26	586	0.35	689	0.45	775	0.54	851	0.63	919	0.72	981	0.81	1039	0.90	1093	1600	
1700		0.29	597	0.39	699	0.49	784	0.59	860	0.69	928	0.78	990	0.88	1048	0.98	1102	1700	
1800		0.32	608	0.42	709	0.54	794	0.64	869	0.74	937	0.85	999	0.95	1057	1.05	1112	1800	
1900		0.35	619	0.46	718	0.58	803	0.69	879	0.80	946	0.91	1009	1.02	1067	1.13	1121	1900	
2000		0.39	630	0.51	728	0.63	812	0.75	888	0.86	956	0.98	1018	1.10	1076	1.21	1130	2000	
2100		0.42	641	0.55	738	0.68	822	0.80	897	0.92	965	1.05	1027	1.17	1085	1.29	1140	2100	
2200		0.46	652	0.59	748	0.73	831	0.86	906	0.98	974	1.12	1036	1.25	1094	1.37	1149	2200	
2300		0.50	663	0.64	758	0.78	841	0.92	915	1.05	983	1.19	1045	1.33	1103	1.46	1158	2300	
2400		0.54	674	0.69	767	0.83	850	0.98	925	1.12	992	1.26	1055	1.41	1113	1.56	1167	2400	
2500		0.58	685	0.74	777	0.89	859	1.04	934	1.18	1001	1.34	1064	1.49	1122	1.63	1177	2500	
2600	3/4 HP	0.63	696	0.79	787	0.95	869	1.10	943	1.25	1010	1.41	1073	1.57	1131	1.72	1186	2600	
2700		0.68	707	0.84	797	1.00	878	1.17	952	1.33	1019	1.49	1082	1.66	1140	1.82	1195	2700	
2800		0.73	718	0.90	807	1.06	887	1.23	961	1.40	1029	1.57	1091	1.74	1149	1.91	1205	2800	
2900		0.78	729	0.95	816	1.13	897	1.30	971	1.47	1038	1.65	1101	1.83	1159	2.00	1214	2900	
3000		0.83	740	1.01	826	1.19	906	1.37	980	1.55	1047	1.73	1110	1.92	1168	2.10	1223	3000	

CFM/MOTOR TABLE: ERV

CFM	Motor Size	ESP = 0.25		ESP = 0.50		ESP = 0.75		ESP = 1.00		ESP = 1.25		ESP = 1.50		ESP = 1.75		ESP = 2.00		Motor Size	CFM
		BHP	RPM	BHP	RPM	BHP	RPM	BHP	RPM	BHP	RPM	BHP	RPM	BHP	RPM	BHP	RPM		
2000	1/2 HP	0.41	656	0.53	752	0.65	835	0.77	908	0.89	975	1.01	1037	1.12	1093	1.23	1147	2000	
2100		0.45	671	0.58	766	0.71	848	0.83	921	0.96	988	1.08	1049	1.20	1106	1.32	1159	2100	
2200		0.49	681	0.62	776	0.76	857	0.89	930	1.02	997	1.15	1058	1.28	1115	1.41	1169	2200	
2300		0.53	691	0.67	785	0.81	866	0.95	939	1.09	1006	1.22	1067	1.36	1124	1.49	1178	2300	
2400		0.58	705	0.73	798	0.87	878	1.01	951	1.16	1017	1.30	1078	1.45	1135	1.59	1189	2400	
2500		3/4 HP	0.63	714	0.78	806	0.93	887	1.08	959	1.23	1025	1.38	1087	1.53	1144	1.68	1198	2500
2600			0.68	727	0.83	818	0.99	898	1.15	970	1.30	1036	1.46	1097	1.62	1154	1.77	1208	2600
2700			0.73	737	0.89	825	1.05	906	1.21	978	1.38	1044	1.54	1105	1.70	1162	1.86	1216	2700
2800			0.78	749	0.95	837	1.12	916	1.29	988	1.46	1054	1.63	1114	1.80	1172	1.96	1225	2800
2900			0.84	759	1.01	844	1.18	923	1.36	995	1.53	1061	1.71	1122	1.88	1179	2.06	1233	2900
3000	0.90		771	1.08	855	1.26	933	1.44	1005	1.62	1070	1.80	1131	1.98	1188	2.16	1242	3000	
3100	0.96		784	1.15	866	1.33	943	1.52	1014	1.71	1080	1.89	1140	2.08	1197	2.27	1251	3100	
3200	1.03		796	1.22	876	1.41	952	1.60	1023	1.80	1089	1.99	1149	2.18	1206	2.37	1259	3200	
3300	1.09		806	1.28	884	1.48	959	1.68	1029	1.88	1095	2.08	1155	2.28	1212	2.48	1266	3300	
3400	1.16		819	1.36	894	1.56	968	1.77	1037	1.97	1103	2.18	1164	2.38	1220	2.59	1274	3400	
3500	1 1/2 HP	1.23	832	1.44	905	1.65	977	1.86	1046	2.07	1111	2.28	1172	2.49	1228	2.70	1282	3500	
3600		1.31	845	1.52	916	1.74	986	1.95	1054	2.17	1119	2.38	1179	2.60	1236	2.82	1290	3600	
3700		1.39	858	1.60	926	1.82	996	2.05	1062	2.27	1126	2.49	1187	2.71	1.23	2.94	1297	3700	
3800		1.47	871	1.69	937	1.92	1005	2.14	1071	2.37	1134	2.60	1194	2.83	1251			3800	
3900		1.56	884	1.78	948	2.01	1014	2.24	1079	2.48	1141	2.71	1201	2.95	1258			3900	
4000		1.65	897	1.87	960														

CONFIGURATIONS

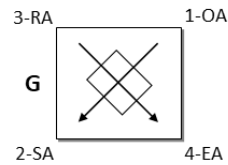
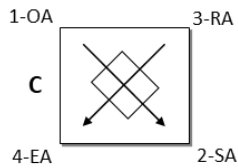

SHOP DRAWINGS – BASIC OPTIONS/CONFIGURATIONS SHOWN

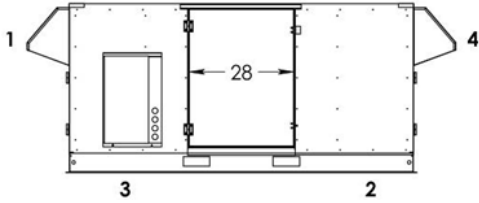

1 = Outside Air (OA) 2 = Supply Air (SA)
3 = Return Air (RA) 4 = Exhaust Air (EA)

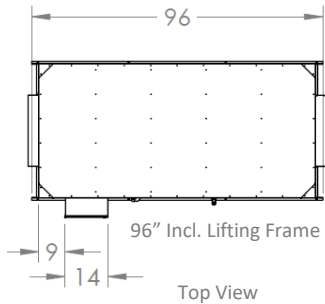
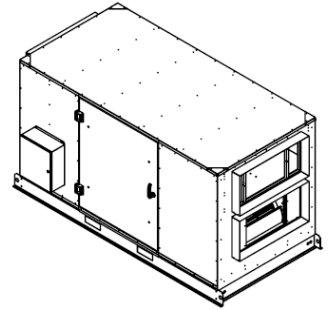
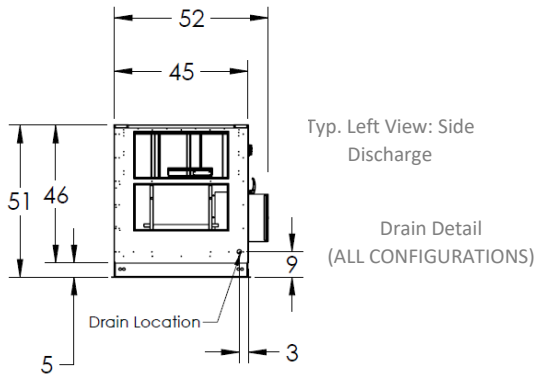

Service Clearances: NU2035						
	Front	Back	Left	Right	Top	Bottom
RECOMMENDED	MINIMUM					
(in)	(in)	(in)	(in)	(in)	(in)	(in)
30	18	0	0	0	0	0

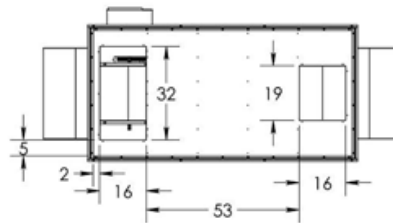
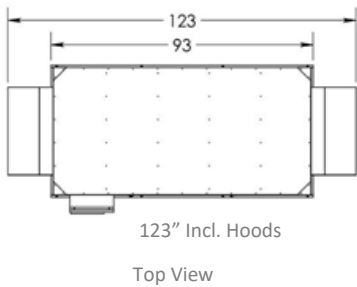
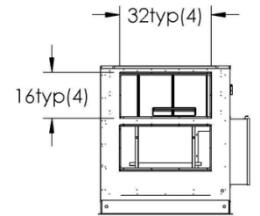

SHOP DRAWINGS – STANDARD 14-inch ROOF CURB, p/n RC303540-14

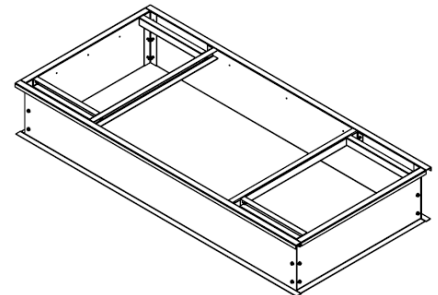
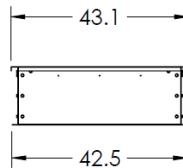
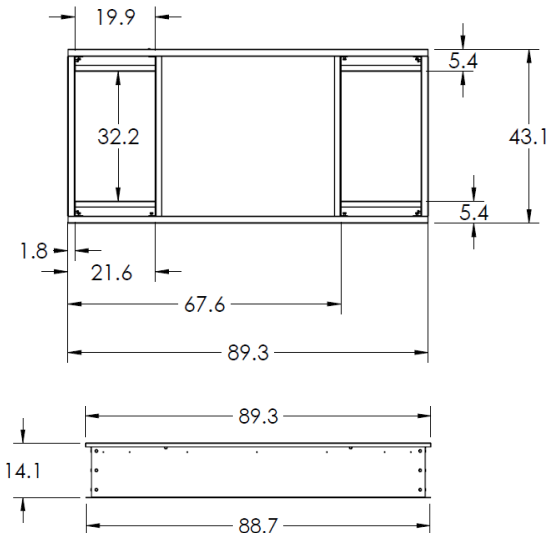

HRV PERFORMANCE – AHRI 1060

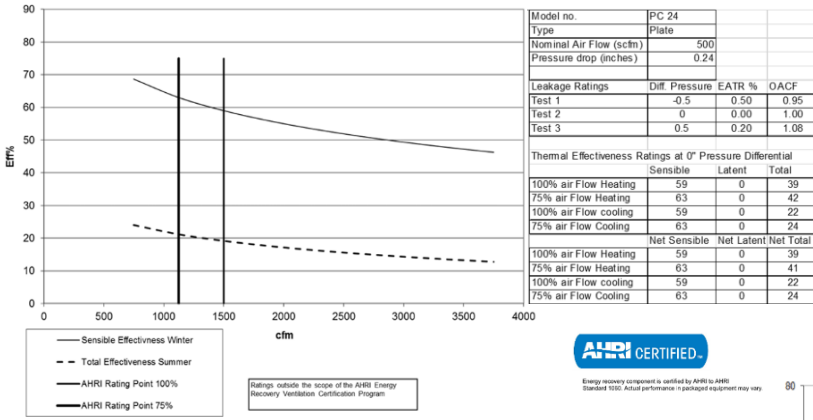

ERV PERFORMANCE – AHRI 1060

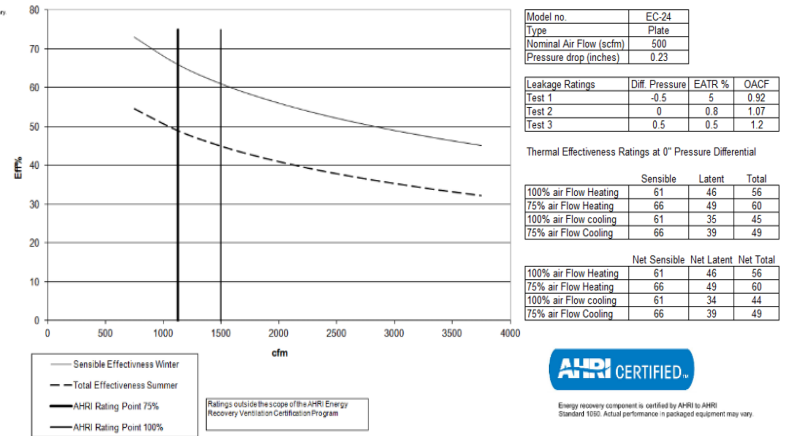

HRV PERFORMANCE FACE & BYPASS – AHRI 1060

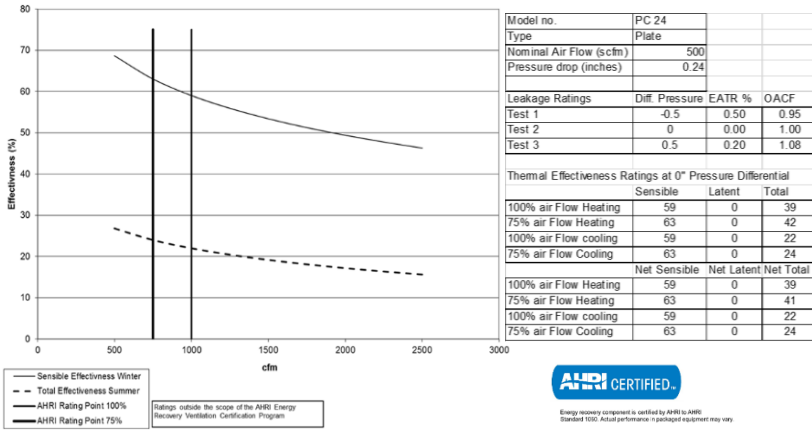

ERV PERFORMANCE FACE & BYPASS – AHRI 1060

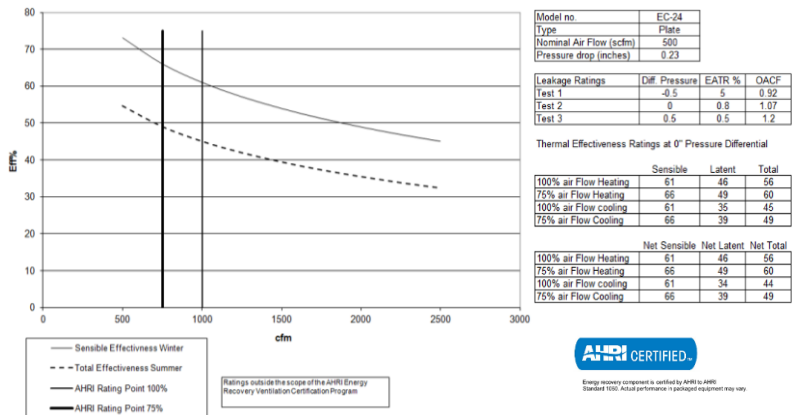

PRODUCT SELECTION/ORDERING INFORMATION: NU2035

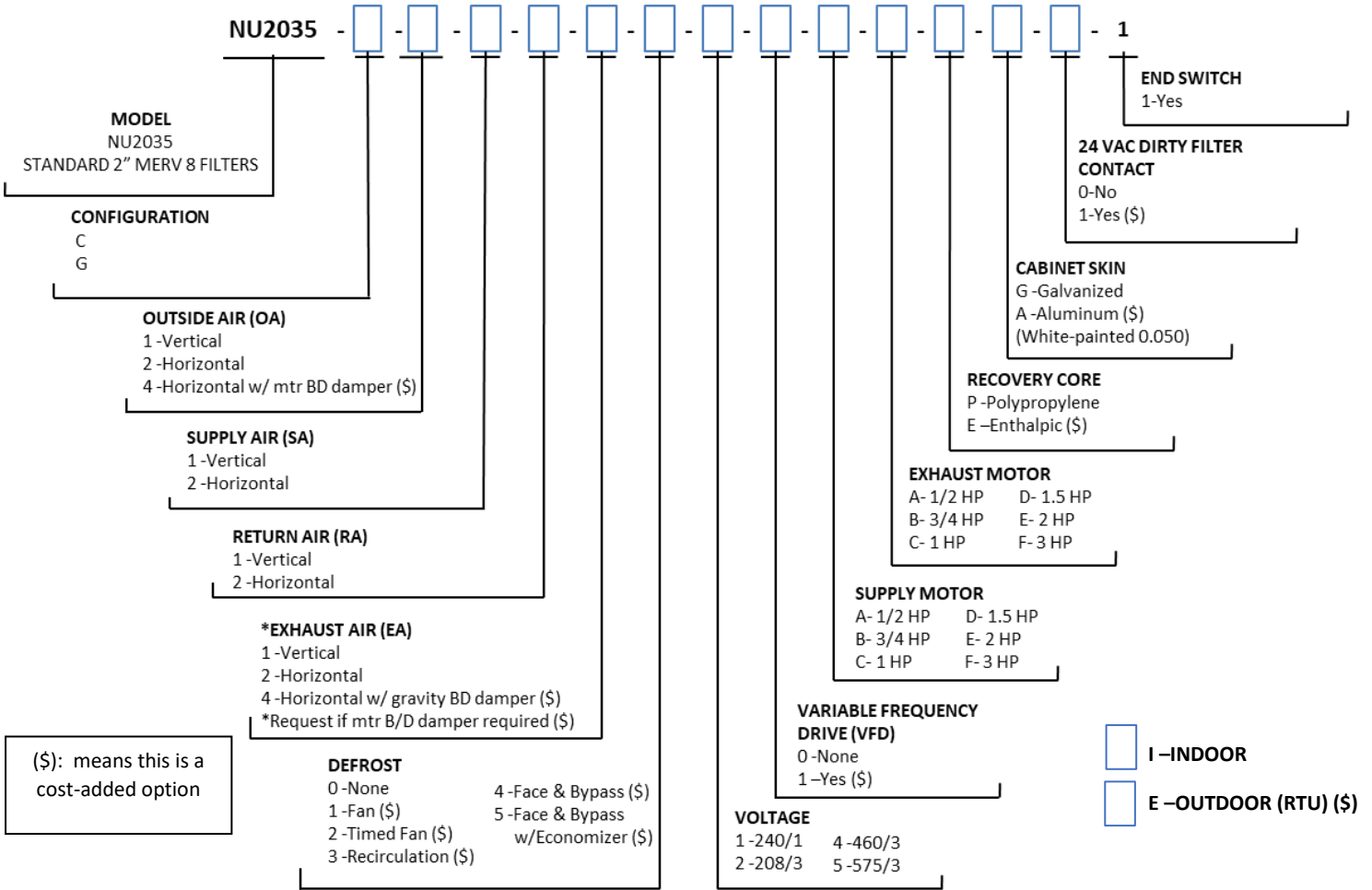

ADD-ON OPTIONS/ACCESSORIES: NU2035

- Motorized Damper, Exhaust Air (EA) (\$)
- 2" MERV 13 Filters (\$)
- Filters, Extra Set (of 6), MERV 8 (\$)
- Filters, Extra Set (of 6), MERV 13 (\$)
- 7-Day Programmable Timer (\$)
- Roof Curb, Uninsulated, 14" (\$)
- Roof Curb, Uninsulated, 18" (\$)
- Roof Curb, Uninsulated, 24" (\$)

FROST CONTROL RECOMMENDATIONS*

TYPE	WINTER DESIGN TEMP.		FACTORY DEFAULT TIMING**	
	° C	° F	RUN	DEFROST
0 - NONE	> -5	> 23	n/a	n/a
1 - FAN SHUT-DOWN	> -10	> 14		
2 - TIMED FAN SHUT-DOWN	> -15	> 5	60 min.	10 min.
3 - RECIRCULATION	> -15	> 5	60 min.	10 min.
4 - FACE & BYPASS	Uninterrupted ventilation and free cooling.			

- 1 - Supply fan shuts off when EA OC (32F). Normal operation resumes when EA is 8C (47F).
- 2 - Supply fan shuts off for defined time when OA is nominal OC (32F).
- 3 - Non-negative pressure defrost when EA is nominal OC (32F).
- 4 - Heat exchanger bypassed in a temperature activated cycle.

*notwithstanding other design considerations such as building pressure, preheat, delivered air temp., etc.
**Field adjustable.

PROJECT INFORMATION

Unit (e.g. HRV-1)	
Project Tag	
Project Location	
Specified By	
Version, Date	

DESIGN INFORMATION

Air Stream	Airflow	ESP
Supply		
Exhaust		
Air Temp. (C or F)	Winter	Summer
RA, DB		
RA, WB		
OA, DB		
OA, WB		