



(Painted Option Shown)

800 – 2000 CFM (NOMINAL)

INDOOR & ROOFTOP APPLICATIONS

MULTIPLE CONFIGURATIONS

FACTORY AIR BALANCED TO PROJECT SPECIFICATIONS

**SPECIFICATIONS**

**CABINET/CONSTRUCTION**

- Double wall construction, 22 ga (standard); 1 inch insulation
  - Duct connections: 24" x 12". Weather hoods c/w bird screen (outdoor unit).
  - Cabinet L x D x H (inches): 46 x 46 x 60 (1170 x 1170 x 1525 mm)
  - Removable access door with 1/4 turn, lockable handle
  - Door-mounted differential pressure ports for air flow balancing
  - NEMA 3R enclosure with non-fused disconnect
  - 1/2" poly drain connections, (bottom only). Drain kit p/n DAK-U provided.
- Unit Weight: 650 lbs (294 kg)      Shipping Weight: 780 lbs (354 kg)  
 Shipping L x D x H: 68 x 56 x 72" (No hoods); 82 x 56 x 72" (W/ hoods)

**CORE: Static Plate, Crossflow. Certified to AHRI 1060**

- HRV: Polypropylene, 2 x p/n PC1721A (AHRI Ref.# PC18)
- ERV: Enthalpic membrane, 2 x p/n EC1721A (AHRI Ref.# EC18)
- FACE & BYPASS: 1 x BP1714 + 2 x PC1714 (HRV), or 2 x EC1714 (ERV)

**MOTORS - FANS - FILTERS**

- 2 x TEFC single-speed motors, 0.5-1.5 HP
- 2 x DWDI belt drive blowers p/n 50071
- 6 x MERV 8 pleated filters (standard), 14 x 17.5 x 2", p/n 50078.

**CONTROL**

- Starter panel has Manual (full-time) or Auto/Remote (24 VAC) options.
- Factory installed VFD's present options for additional control means.
- 7-Day programmable timer p/n 50395

**FROST CONTROL – 6 OPTIONS (details see: PRODUCT SELECTION)**

- None      - Face & Bypass (F&P)
- Exhaust only (temperature ON/OFF)      - F&P with Economizer
- Timed exhaust (temperature ON/Timed OFF)
- Recirculation

**OPTIONS & ACCESSORIES**

- 0.050 painted (white) aluminum outer skin
- Factory installed VFD's
- MERV 13 filters, 14 x 17.5 x 2" p/n 50211
- Dirty filter contacts/sensors
- Insulated, low leakage Outside Air backdraft damper (motorized)
- Exhaust Air backdraft damper (gravity OR motorized/insulated)
- Non-insulated roof curb 14" (standard). Custom sizes: 18", 24".
- 7-Day programmable timer, p/n 50395

**WARRANTY - COMPLIANCE**

- 2 years on internal components
- 15 years on polypropylene (HRV) cores; 5 years on Enthalpy (ERV) cores
- NU0820 conforms to CSA SPE1000

**CFM/MOTOR TABLE: HRV**

CFM	Motor Size	ESP = 0.25		ESP = 0.50		ESP = 0.75		ESP = 1.00		ESP = 1.25		ESP = 1.5		Motor Size	CFM
		BHP	RPM	BHP	RPM	BHP	RPM	BHP	RPM	BHP	RPM	BHP	RPM		
800	1/2 HP	0.16	723	0.23	879	0.32	1006	0.41	1115	0.5	1209	0.59	1295	3/4 HP	800
900		0.19	758	0.28	909	0.37	1035	0.47	1145	0.57	1242	0.67	1327		900
1000		0.23	796	0.33	943	0.43	1067	0.53	1175	0.64	1273	0.75	1361	1 HP	1000
1100		0.27	826	0.37	969	0.48	1091	0.6	1199	0.71	1296	0.83	1385		1100
1200		0.32	860	0.43	998	0.55	1118	0.67	1225	0.79	1322	0.92	2.06		1200
1300		0.37	886	0.49	1021	0.61	1139	0.74	1245	0.87	1342	1	1431		1300
1400	0.43	917	0.55	1047	0.68	1163	0.82	1268	0.96	1364	1.1	1452	1.5 HP	1400	
1500	0.48	942	0.62	1067	0.75	1181	0.9	1285	1.04	1381	1.19	1469		1500	
1600	0.55	971	0.69	1092	0.83	1203	0.98	1306	1.14	1400	1.29	1488		1600	
1700	3/4 HP	0.62	1000	0.77	1116	0.92	1224	1.07	1325	1.23	1418	1.4	1506	N/A	1700
1800		0.7	1027	0.84	1135	1	1240	1.16	1340	1.33	1432	1.5	1519		1800
1900	1 HP	0.78	1057	0.93	1158	1.09	1260	1.26	1357	1.44	1449			N/A	1900
2000		0.87	1083	1.02	1177	1.18	1276	1.36	1371						2000

**CFM/MOTOR TABLE: HRV – FACE AND BYPASS**

CFM	Motor Size	ESP = 0.25		ESP = 0.50		ESP = 0.75		ESP = 1.00		ESP = 1.25		ESP = 1.5		Motor Size	CFM
		BHP	RPM	BHP	RPM	BHP	RPM	BHP	RPM	BHP	RPM	BHP	RPM		
800	1/2 HP	0.22	850	0.3	983	0.39	1095	0.48	1191	0.57	1278	0.67	1359	3/4 HP	800
900		0.27	898	0.36	1026	0.46	1137	0.56	1234	0.66	1320	0.76	1400		900
1000		0.32	937	0.42	1062	0.53	1171	0.64	1269	0.75	1358	0.86	1437	1 HP	1000
1100		0.38	979	0.49	1100	0.61	1207	0.72	1304	0.84	1392	0.96	1474		1100
1200		0.45	1018	0.57	1136	0.69	1241	0.81	1337	0.94	1424	1.07	1506		1200
1300		0.52	1055	0.65	1170	0.78	1273	0.91	1367	1.04	1454	1.18	1535		1.5 HP
1400	3/4 HP	0.6	1090	0.73	1202	0.87	1303	1.01	1396	1.15	1483	1.3	1563	1400	
1500		0.68	1123	0.82	1232	0.97	1332	1.11	1424	1.26	1509	1.42	1589	1500	

**CFM/MOTOR TABLE: ERV**

CFM	Motor Size	ESP = 0.25		ESP = 0.50		ESP = 0.75		ESP = 1.00		ESP = 1.25		ESP = 1.5		Motor Size	CFM
		BHP	RPM	BHP	RPM	BHP	RPM	BHP	RPM	BHP	RPM	BHP	RPM		
800	1/2 HP	0.18	790	0.27	932	0.35	1052	0.44	1153	0.53	1244	0.63	1327	3/4 HP	800
900		0.23	835	0.32	972	0.42	1090	0.51	1193	0.61	1283	0.71	1366		900
1000		0.28	876	0.38	1010	0.48	1125	0.59	1227	0.7	1320	0.81	1402	1 HP	1000
1100		0.33	914	0.44	1044	0.55	1157	0.67	1259	0.78	1351	0.9	1436		1100
1200		0.39	951	0.51	1077	0.62	1188	0.75	1288	0.87	1379	1	1464		1200
1300		0.45	985	0.58	1107	0.7	1217	0.83	1316	0.97	1406	1.1	1491		1.5 HP
1400	3/4 HP	0.53	1022	0.66	1141	0.79	1248	0.93	1345	1.07	1435	1.22	1519	1400	
1500		0.6	1053	0.74	1168	0.88	1273	1.03	1370	1.17	1459	1.33	1542	1500	
1600	1 HP	0.68	1083	0.82	1195	0.97	1298	1.12	1393	1.28	1481	1.44	1564	N/A	1600
1700		0.77	1116	0.92	1224	1.07	1325	1.23	1418	1.4	1506				1700
1800		0.86	1148	1.02	1253	1.18	1351	1.35	1443						1800
1900		0.96	1175	1.12	1276	1.29	1372	1.46	1463						1900
2000	1.5 HP	1.06	1205	1.23	1303	1.41	1397							2000	

**CFM/MOTOR TABLE : ERV – FACE AND BYPASS**

CFM	Motor Size	ESP = 0.25		ESP = 0.50		ESP = 0.75		ESP = 1.00		ESP = 1.25		ESP = 1.5		Motor Size	CFM
		BHP	RPM	BHP	RPM	BHP	RPM	BHP	RPM	BHP	RPM	BHP	RPM		
800	1/2 HP	0.29	963	0.38	1078	0.46	1176	0.56	1265	0.65	1346	0.75	1422	3/4 HP	800
900		0.36	1021	0.45	1133	0.55	1231	0.65	1317	0.76	1397	0.86	1472		900
1000		0.43	1076	0.54	1183	0.65	1280	0.76	1367	0.87	1446	0.98	1519	1 HP	1000
1100	3/4 HP	0.52	1131	0.64	1235	0.75	1329	0.87	1416	1	1495	1.12	1567		1.5 HP
1200		0.62	1184	0.74	1284	0.87	1376	1	1461	1.13	1540	1.26	1614	1200	

### CONFIGURATIONS

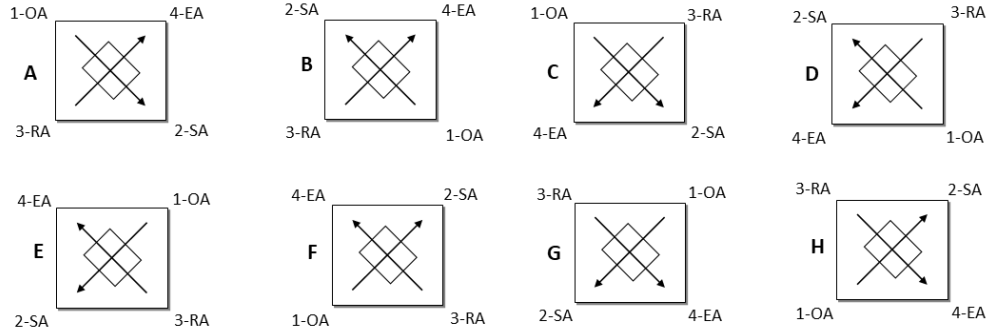

### SHOP DRAWINGS – BASIC OPTIONS/CONFIGURATIONS SHOWN

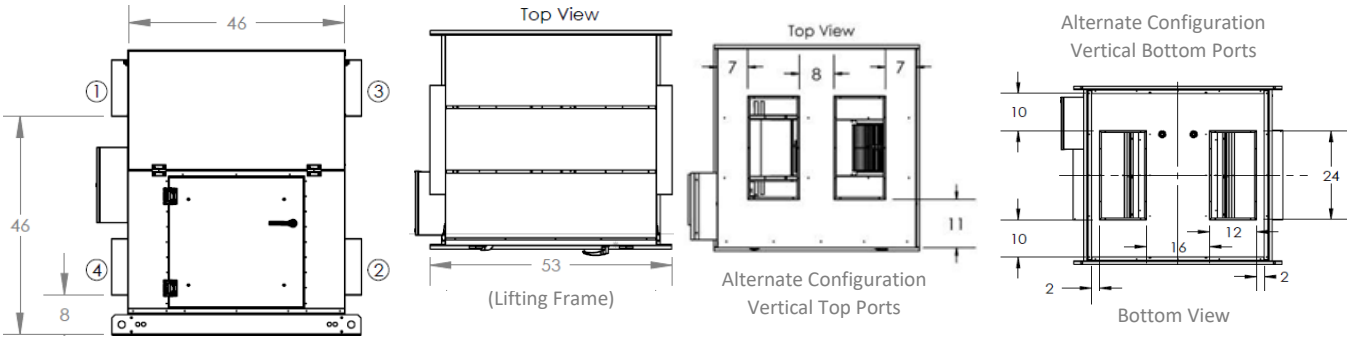

1 = Outside Air (OA) 2 = Supply Air (SA)  
3 = Return Air (RA) 4 = Exhaust Air (EA)

Service Clearances: NU0820						
RECOMMENDED	MINIMUM	Back	Left	Right	Top	Bottom
(in)	(in)	(in)	(in)	(in)	(in)	(in)
30	24	0	*21	*21	0	0

\*Allows for starter box access according to orientation/placement of unit.

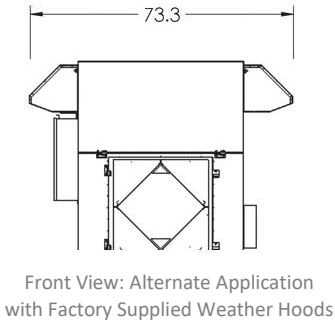
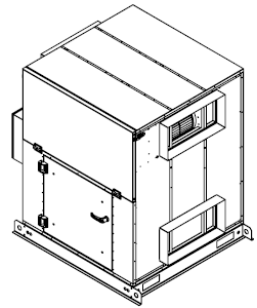

Front View: Alternate Application with Factory Supplied Weather Hoods

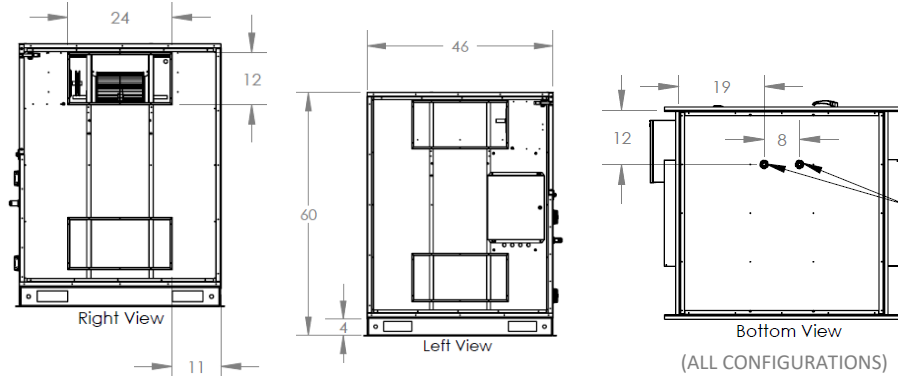

Drain Location  
1/2" ID, 5/8" OD  
Fittings, Poly Pipe  
Supplied

### SHOP DRAWINGS – STANDARD 14-inch ROOF CURB, p/n RC0820-14

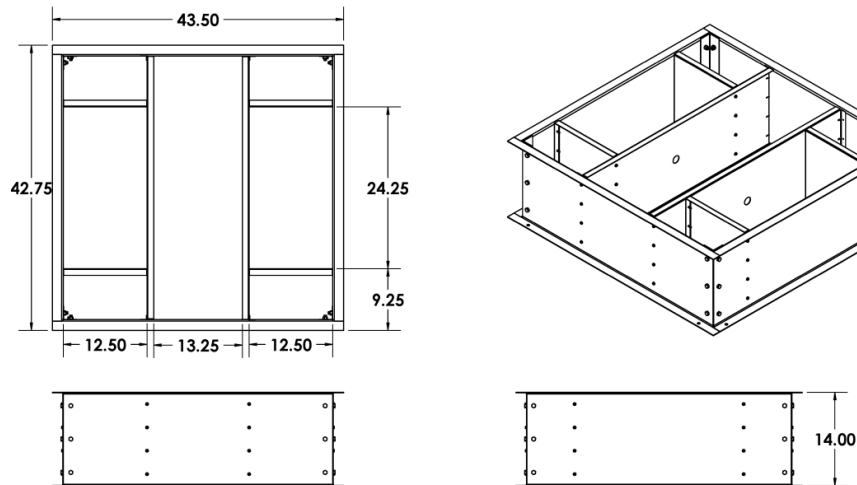

### HRV PERFORMANCE – AHRI 1060

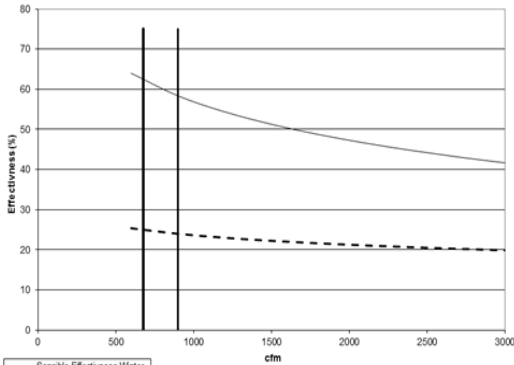

Model no.	PC 18
Type	Plate
Nominal Air Flow (scfm)	300
Pressure drop (inches)	0.12

Leakage Ratings	Diff. Pressure	EATR %	OACF
Test 1	-0.5	0.50	0.95
Test 2	0	0.00	1.00
Test 3	0.5	0.20	1.08

Thermal Effectiveness Ratings at 0° Pressure Differential			
	Sensible	Latent	Total
100% air Flow Heating	64	0	40
75% air Flow Heating	68	0	43
100% air Flow cooling	62	0	24
75% air Flow Cooling	66	0	25

	Net Sensible	Net Latent	Net Total
100% air Flow Heating	64	0	40
75% air Flow Heating	68	0	43
100% air Flow cooling	62	0	23
75% air Flow Cooling	66	0	25



Energy recovery component is certified by AHRI to AHRI Standard 1060. Actual performance in packaged equipment may vary.

### HRV PERFORMANCE FACE & BYPASS – AHRI 1060

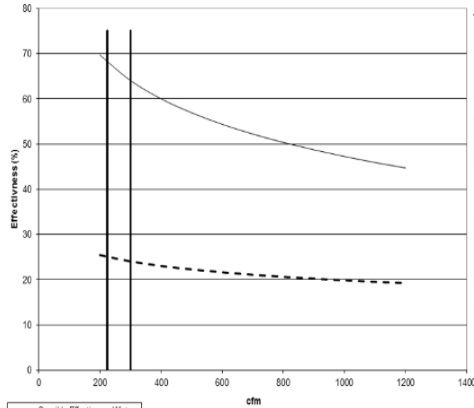

Model no.	PC 18
Type	Plate
Nominal Air Flow (scfm)	300
Pressure drop (inches)	0.12

Leakage Ratings	Diff. Pressure	EATR %	OACF
Test 1	-0.5	0.50	0.95
Test 2	0	0.00	1.00
Test 3	0.5	0.20	1.08

Thermal Effectiveness Ratings at 0° Pressure Differential			
	Sensible	Latent	Total
100% air Flow Heating	64	0	40
75% air Flow Heating	68	0	43
100% air Flow cooling	62	0	24
75% air Flow Cooling	66	0	25

	Net Sensible	Net Latent	Net Total
100% air Flow Heating	64	0	40
75% air Flow Heating	68	0	43
100% air Flow cooling	62	0	23
75% air Flow Cooling	66	0	25



Energy recovery component is certified by AHRI to AHRI Standard 1060. Actual performance in packaged equipment may vary.

### ERV PERFORMANCE – AHRI 1060

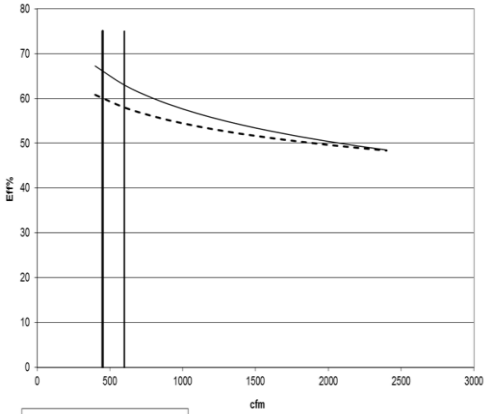

Model no.	EC-18
Type	Plate
Nominal Air Flow (scfm)	300
Pressure drop (inches)	0.33

Leakage Ratings	Diff. Pressure	EATR %	OACF
Test 1	-0.5	5.00	0.92
Test 2	0	0.80	1.07
Test 3	0.5	0.50	1.20

Thermal Effectiveness Ratings at 0° Pressure Differential			
	Sensible	Latent	Total
100% air Flow Heating	63	47	58
75% air Flow Heating	66	49	60
100% air Flow cooling	63	36	46
75% air Flow Cooling	66	39	49

	Net Sensible	Net Latent	Net Total
100% air Flow Heating	63	47	57
75% air Flow Heating	66	49	60
100% air Flow cooling	63	35	46
75% air Flow Cooling	66	39	49



Energy recovery component is certified by AHRI to AHRI Standard 1060. Actual performance in packaged equipment may vary.

### ERV PERFORMANCE FACE & BYPASS – AHRI 1060

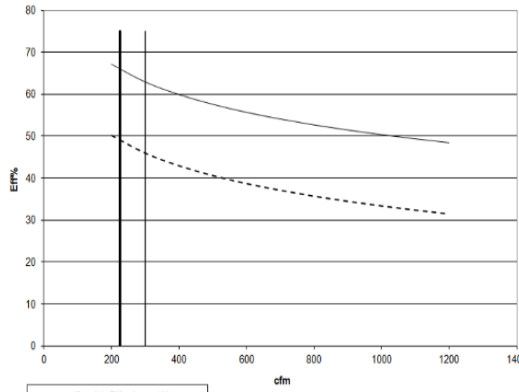

Model no.	EC-18
Type	Plate
Nominal Air Flow (scfm)	300
Pressure drop (inches)	0.33

Leakage Ratings	Diff. Pressure	EATR %	OACF
Test 1	-0.5	5	0.92
Test 2	0	0.8	1.07
Test 3	0.5	0.5	1.2

Thermal Effectiveness Ratings at 0° Pressure Differential			
	Sensible	Latent	Total
100% air Flow Heating	63	47	58
75% air Flow Heating	66	49	60
100% air Flow cooling	63	36	46
75% air Flow Cooling	66	39	49

	Net Sensible	Net Latent	Net Total
100% air Flow Heating	63	47	57
75% air Flow Heating	66	49	60
100% air Flow cooling	63	35	46
75% air Flow Cooling	66	39	49



Energy recovery component is certified by AHRI to AHRI Standard 1060. Actual performance in packaged equipment may vary.

**PRODUCT SELECTION/ORDERING INFORMATION: NU0820**

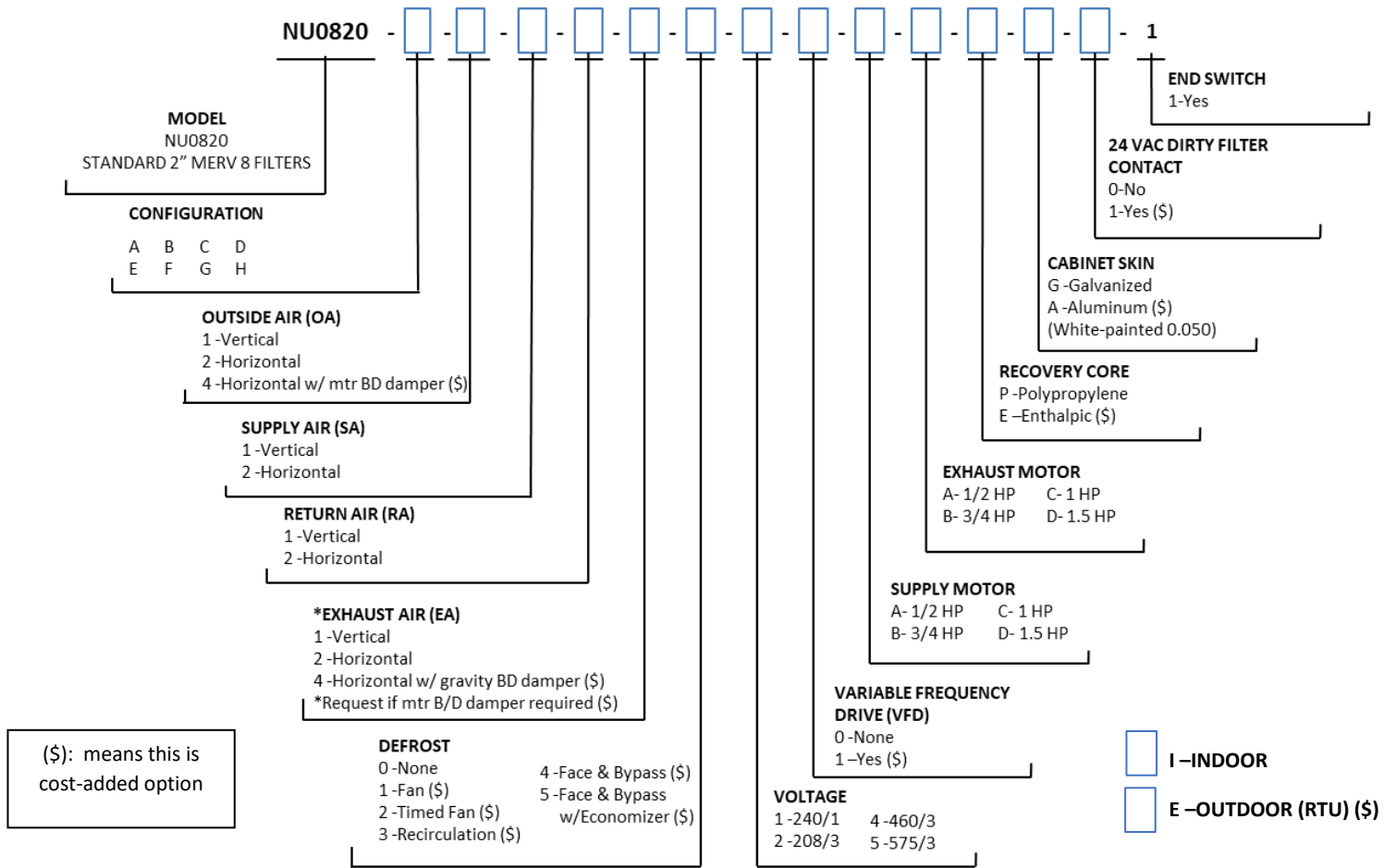

**ADD-ON OPTIONS/ACCESSORIES: NU0820**

- Motorized Damper, Exhaust Air (EA) (\$)
- 2" MERV 13 Filters (\$)
- Filters, Extra Set (of 6), MERV 8 (\$)
- Filters, Extra Set (of 6), MERV 13 (\$)
- 7-Day Programmable Timer (\$)
- Roof Curb, Uninsulated, 14" (\$)
- Roof Curb, Uninsulated, 18" (\$)
- Roof Curb, Uninsulated, 24" (\$)

**FROST CONTROL RECOMMENDATIONS\***

TYPE	WINTER DESIGN TEMP.		FACTORY DEFAULT TIMING**	
	° C	° F	RUN	DEFROST
0 - NONE	> -5	> 23	n/a	n/a
1 - FAN SHUT-DOWN	> -10	> 14		
2 - TIMED FAN SHUT-DOWN	> -15	> 5	60 min.	10 min.
3 - RECIRCULATION	> -15	> 5	60 min.	10 min.
4 - FACE & BYPASS	Uninterrupted ventilation and free cooling.			

- 1 - Supply fan shuts off when EA OC (32F). Normal operation resumes when EA is 8C (47F).
- 2 - Supply fan shuts off for defined time when OA is nominal OC (32F).
- 3 - Non-negative pressure defrost when EA is nominal OC (32F).
- 4 - Heat exchanger bypassed in a temperature activated cycle.

\*notwithstanding other design considerations such as building pressure, preheat, delivered air temp., etc.  
\*\*Field adjustable.

**PROJECT INFORMATION**

Unit (e.g. HRV-1)	
Project Tag	
Project Location	
Specified By	
Version, Date	

**DESIGN INFORMATION**

Air Stream	Airflow	ESP
Supply		
Exhaust		
<b>Air Temp. (C or F)</b>	<b>Winter</b>	<b>Summer</b>
RA, DB		
RA, WB		
OA, DB		
OA, WB		